

Ball Valves

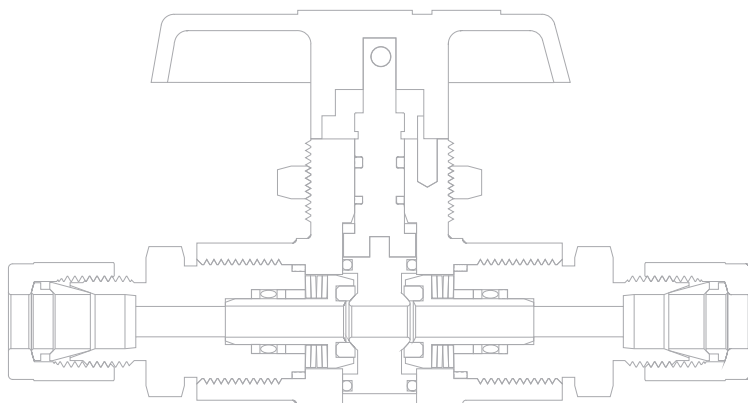

Climate Control
Electromechanical
Filtration
Fluid & Gas Handling
Hydraulics
Process Control
Sealing & Shielding

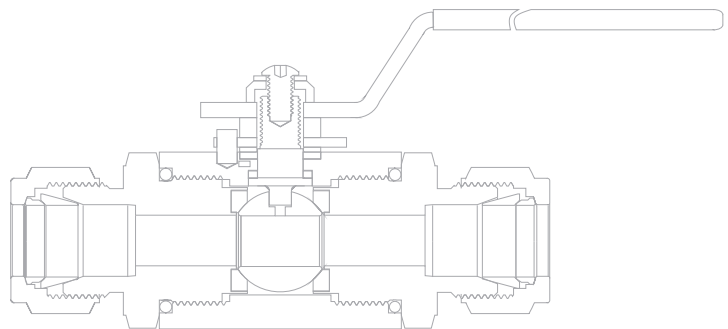

CONTENTS

Ball Valves

Trunnion High Pressure 47 and 47H Series	1
3-piece Thread-loaded Seat Patent Design 44 Series	9
3-piece General Pressure 45 Series	15
Bar Stock Valve Body 42 Series	20
Hex Bar Stock Valve Body 43 Series	27
High Performance 41 Series	31
One-piece Instrumentation Ball Valve 46 Series	38

Trunnion High Pressure Ball Valves

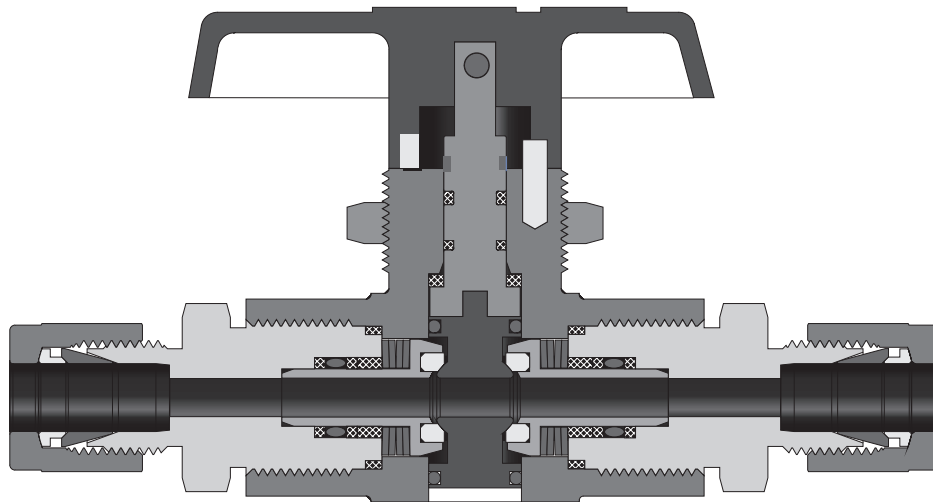

47 and 47H Series

- Compact, maximum-flow design.
- Low operating torque.
- Heavy-duty handle indicates flow direction.
- Bottom-loaded stem:
 - Prevents stem blowout
 - Enhances system safety
- Trunnion-style ball:
 - Prevents ball blowout
 - Contributes to low operating torque.
- Spring-loaded seats:
 - Provide leak-tight integrity in both low- and high-pressure systems
 - Contribute to low operating torque
 - Ceduce seat wear from pressure surges
- Straight and 3-way flow patterns.
- Stainless steel and alloy 400 steel body materials can be selected.
- 47 series pressures up to 6000 psig (413 bar).
- 47H series pressures up to 10 000 psig (689 bar).
- Temperatures up to 450°F (232°C) with PEEK seat;
- Every valve is 100% factory tested with nitrogen.
- Pressures up to 6000 psig (413 bar).
- Temperatures up to 450° F (232° C) with PTFE packing;

Pressure vs. Temperature

47 Series with PTFE Seat

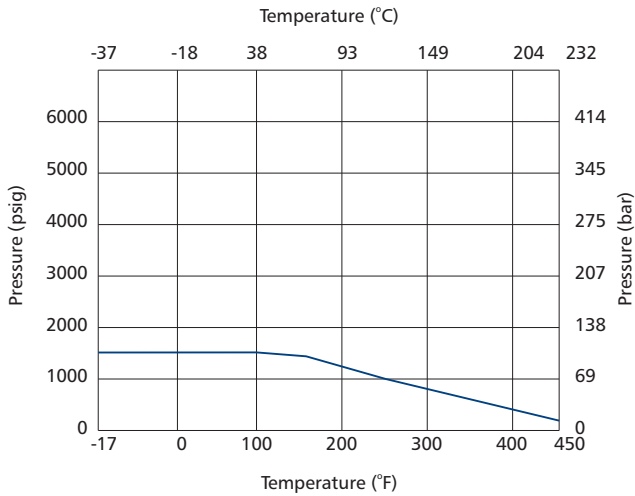

47 Series with PCTFE Seat

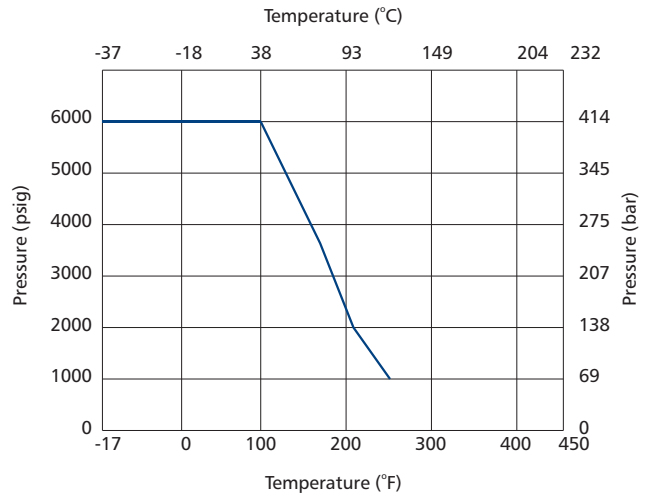

47 Series with PEEK Seat

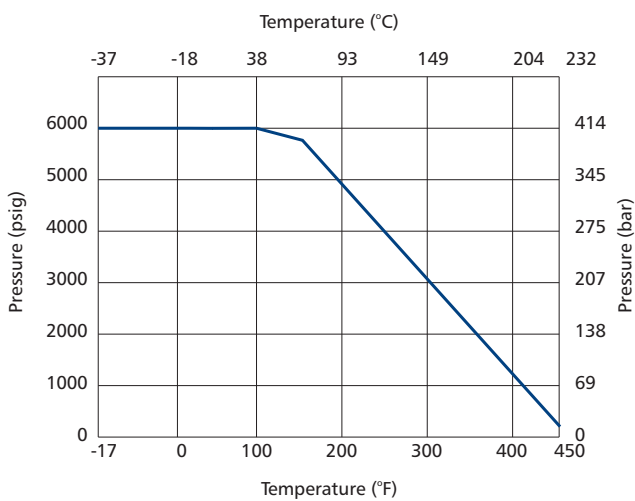

47H Series with PEEK Seat

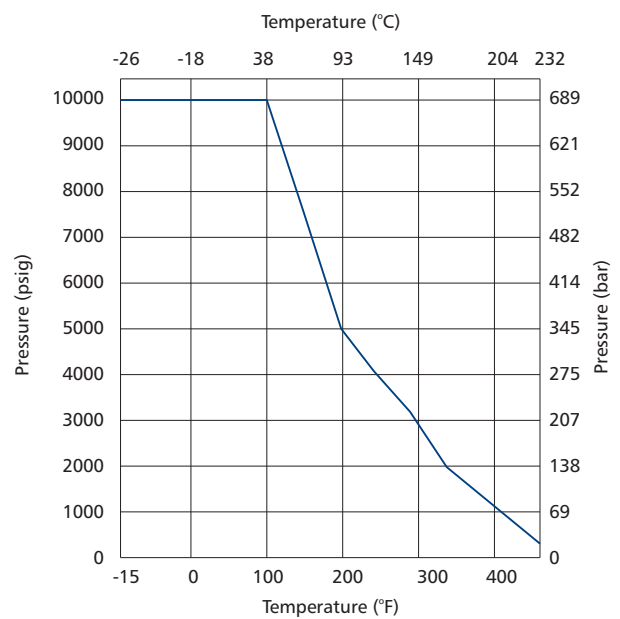

1. Graphs are for 2-way valves only
2. Maximum working pressure for 3-way valves:
 6000 psig: connection 1 as inlet, connection 2 and connection 3 as outlet
 3000 psig: connection 2 and connection 3 as inlet, connection 1 as outlet

Flow Data at 70°F (20°C)

47 Series 2-way

0.187" (4.75 mm) orifice, 1.2 Cv

Inlet Pressure psig (bar)	Pressure Drop (Δp) psig (bar)	Air Flow std ft ³ /min (std L/min)	Water Flow U.S. gal/min (L/min)
1000 (69)	10 (0.69)	14 (334)	3.5 (13)
3000 (207)	50 (3.45)	30 (834)	7.5 (28)
6000 (414)	100 (6.89)	60 (1670)	11.0 (41)

47 Series 3-way

0.187" (4.75 mm) orifice, 0.75 Cv

Inlet Pressure psig (bar)	Pressure Drop (Δp) psig (bar)	Air Flow std ft ³ /min (std L/min)	Water Flow U.S. gal/min (L/min)
1000 (69)	10 (0.69)	10 (275)	3.0 (11)
3000 (207)	50 (3.45)	23 (630)	7.0 (26)
6000 (414)	100 (6.89)	42 (1150)	9.5 (35)

47H Series 2-way

0.187" (4.75 mm) orifice, 1.2 Cv

Inlet Pressure psig (bar)	Pressure Drop (Δp) psig (bar)	Air Flow std ft ³ /min (std L/min)	Water Flow U.S. gal/min (L/min)
1000 (69)	150 (10.3)	90 (2550)	15 (56)
6000 (414)	600 (41.4)	345 (9660)	30 (111)
10000 (689)	1000 (68.9)	560 (15680)	40 (148)

47H Series 3-way

0.187" (4.75 mm) orifice, 0.75 Cv

Inlet Pressure psig (bar)	Pressure Drop (Δp) psig (bar)	Air Flow std ft ³ /min (std L/min)	Water Flow U.S. gal/min (L/min)
1000 (69)	150 (10.3)	55 (1540)	10 (37.0)
6000 (414)	600 (41.4)	200 (5600)	20 (74.0)
10000 (689)	1000 (68.9)	330 (9240)	25 (92.5)

Standard Materials of Construction

47 Series

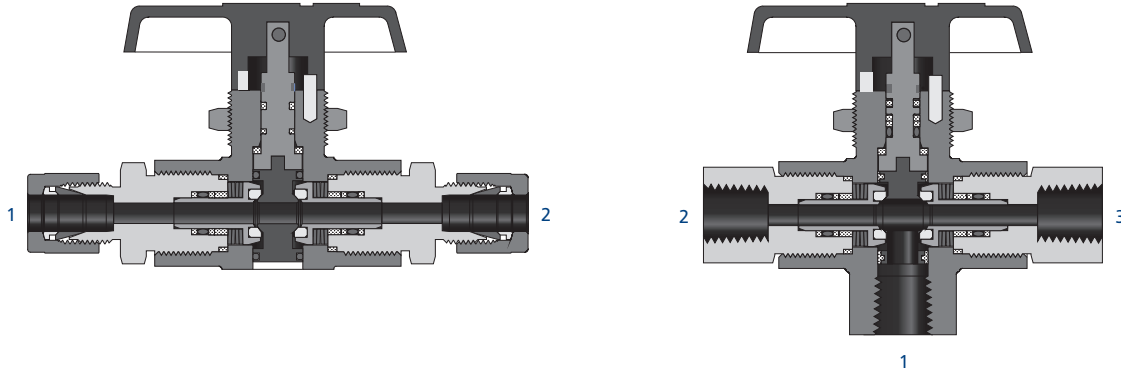

Item	Component	Valve Body Material			
		316 Stainless Steel		Alloy 400	
		2-way	3-way	2-way	3-way
Material Grade/ASTM Specification					
1	Handle	Nylon or aluminium			
2	Panel Nut	316 SS/B783			
3	Body	316 SS/A479		Alloy 400/B164	
4	End Connector	316 SS/A479		Alloy R-405/B164	
5	Seat Retainer Guide	Reinforced PTFE			
6	Seat Retainer O-ring	Fluorocarbon FKM			
7	Seat Carrier Guide	316 SS/A276		Alloy R-405/B164	
8	End Connector Seal	PTFE/D1710			
9	Trunnion Bearing	Fluorocarbon FKM	PEEK	Fluorocarbon FKM	PEEK
10	Ball	316 SS/A276	S21800/A276	Alloy R-405/B164	
11	Seat Spring	Alloy X-750/AMS 5542			
12	Seat Retainer	316 SS/A276		Alloy R-405/B164	
13	Seat	PTFE or PEEK or PCTFE			
14	Stem	316 SS/A276		Alloy R-405/B164	
15	Stem Washer	Reinforced PTFE	PEEK	Reinforced PTFE	PEEK
16	Stem O-ring	—	Fluorocarbon FKM	—	Fluorocarbon FKM
17	Primary Stem Backup Ring	PTFE/D1710			
18	Pin	Stainless Steel			
19	Set Screw	S17400 SS			
20	Secondary Stem Backup Ring	—	PEEK	—	PEEK
Lubricants		Molybdenum and Tungsten disulfide and Fluorinated-based			

1. Ball trunnions are PTFE coated in 47 series 2-way valve.
2. Other materials are available upon request, refer to the ordering information.

47H Series

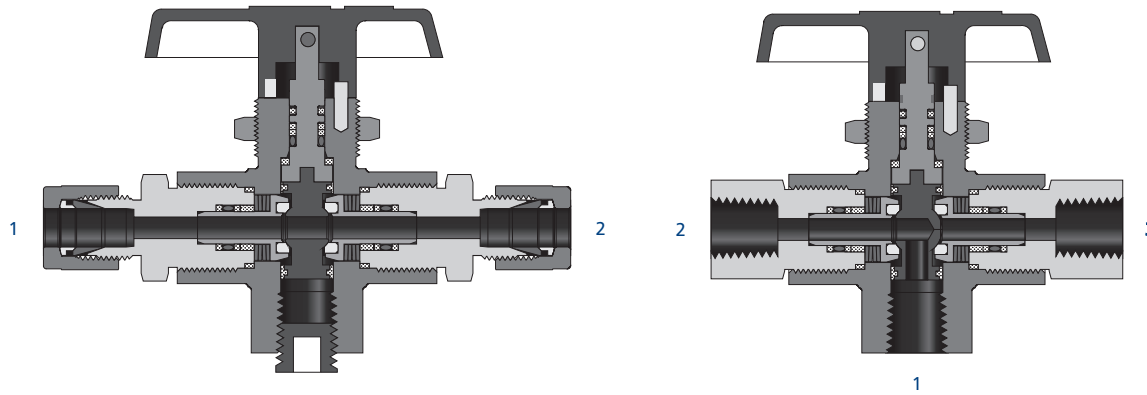

Item	Component	2-way	3-way
		Material Grade/ASTM Specification	
1	Handle	Nylon or aluminium	
2	Panel Nut	316 SS/B783	
3	Body	316 SS/A479	
4	End Connector	316 SS/A479	
5	Seat Retainer Guide	Reinforced PTFE	
6	Seat Retainer O-ring	Fluorocarbon FKM	
7	Seat Carrier Guide	316 SS/A276	
8	End Connector Seal	PTFE/D1710	
9	Trunnion Bearing	Fluorocarbon FKM	
10	Plug	316 SS/A276	
11	Ball	S21800/A276	
12	Seat Spring	Alloy X-750/AMS 5542	
13	Seat Retainer	316 SS/A276	
14	Seat	PEEK	
15	Stem	316 SS/A276	
16	Stem Washer	PEEK	
17	Stem O-ring	Fluorocarbon FKM	
18	Stem Back-up Ring	PTFE/D1710	
19	Pin	304 SS	
20	Set Screw	S17400/A564	
21	Stem Backup Ring	PEEK	
Lubricants		Molybdenum and Tungsten disulfide and Fluorinated-based	

1. Ball trunnions are Xylan® coated in 47H series 2-way valve.
2. Other materials are available upon request, refer to the ordering information.

Dimensions

Dimensions in inches (millimeters), are for reference only and are subject to change.

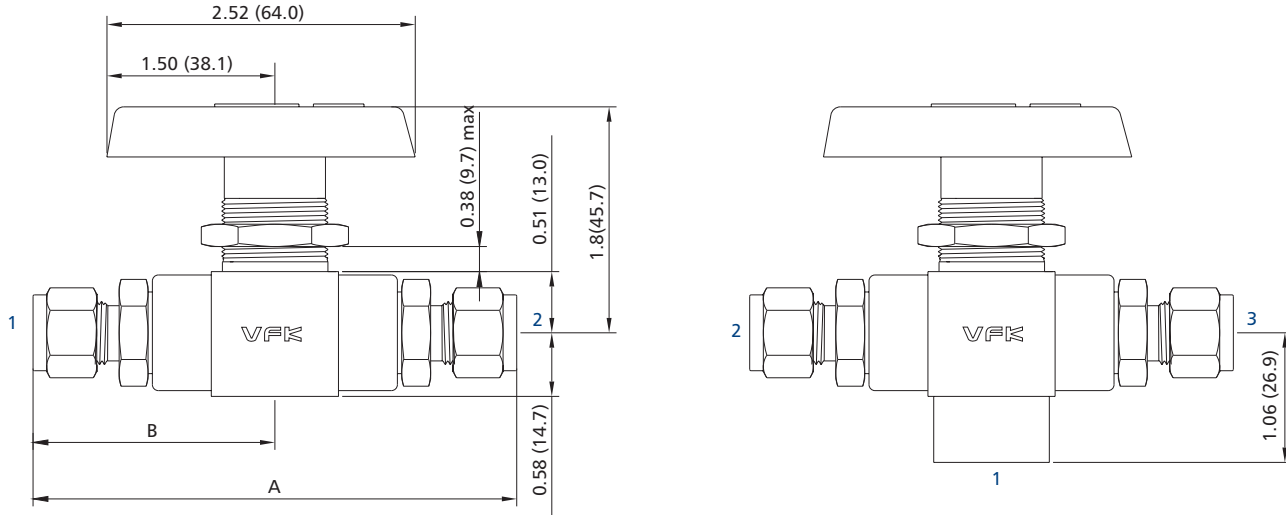

2-way Valve

Basic Ordering Number		Connection Size		Cv	Dimension, in. (mm)		Panel Hole Drill in. (mm)
47 Series	47H Series	Connection 1	Connection 2		A	B	
<input type="checkbox"/> 47-FN2	<input type="checkbox"/> 47H-FN2	1/8 Female NPT	1/8 Female NPT	1.2	2.94 (74.7)	1.47 (37.3)	29/32 (23.0)
<input type="checkbox"/> 47-FN4	_____	1/4 Female NPT	1/4 Female NPT		3.93 (99.8)	1.97 (50.0)	
_____	<input type="checkbox"/> 47H-FN4		1/2 Female NPT		1/2 Female NPT	4.25 (108.0)	
<input type="checkbox"/> 47-FN8	_____	1/4" VFK	1/4" VFK		4.14 (105.2)	2.07 (52.6)	
<input type="checkbox"/> 47-FX4	<input type="checkbox"/> 47H-FX4	3/8" VFK	3/8" VFK		4.39 (111.5)	2.19 (55.6)	
<input type="checkbox"/> 47-FX6	<input type="checkbox"/> 47H-FX6	1/2" VFK	1/2" VFK		4.60 (116.8)	2.30 (58.4)	
<input type="checkbox"/> 47-FX8	<input type="checkbox"/> 47H-FX8	6 mm VFK	6 mm VFK		4.14 (105.2)	2.07 (52.6)	
<input type="checkbox"/> 47-MX6	<input type="checkbox"/> 47H-MX6	8 mm VFK	8 mm VFK		4.15 (105.4)	2.07 (52.6)	
<input type="checkbox"/> 47-MX8	<input type="checkbox"/> 47H-MX8	10 mm VFK	10 mm VFK		4.41 (112.0)	2.20 (55.9)	
<input type="checkbox"/> 47-MX10	<input type="checkbox"/> 47H-MX10	12 mm VFK	12 mm VFK		4.60 (116.8)	2.30 (58.4)	
<input type="checkbox"/> 47-MX12	<input type="checkbox"/> 47H-MX12						

3-way Valve

Basic Ordering Number		Connection Size			Cv	Dimension, in. (mm)		Panel Hole Drill in. (mm)
47 Series	47H Series	Connection 1	Connection 2	Connection 3		A	B	
<input type="checkbox"/> 47-FN2-3	<input type="checkbox"/> 47H-FN2-3	1/4 Female NPT	1/8 Female NPT	1/8 Female NPT	0.75	2.94 (74.7)	1.47 (37.3)	29/32 (23.0)
<input type="checkbox"/> 47-FN4-3	_____		1/4 Female NPT	1/4 Female NPT		3.93 (99.8)	1.97 (50.0)	
_____	<input type="checkbox"/> 47H-FN4-3		1/4" VFK	1/4" VFK		4.14 (105.2)	2.07 (52.6)	
<input type="checkbox"/> 47-FX4-3	<input type="checkbox"/> 47H-FX4-3		3/8" VFK	3/8" VFK		4.39 (111.5)	2.19 (55.6)	
<input type="checkbox"/> 47-FX6-3	<input type="checkbox"/> 47H-FX6-3		1/2" VFK	1/2" VFK		4.60 (116.8)	2.30 (58.4)	
<input type="checkbox"/> 47-FX8-3	<input type="checkbox"/> 47H-FX8-3		6 mm VFK	6 mm VFK		4.14 (105.2)	2.07 (52.6)	
<input type="checkbox"/> 47-MX6-3	<input type="checkbox"/> 47H-MX6-3		8 mm VFK	8 mm VFK		4.15 (105.4)	2.07 (52.6)	
<input type="checkbox"/> 47-MX8-3	<input type="checkbox"/> 47H-MX8-3		10 mm VFK	10 mm VFK		4.41 (112.0)	2.20 (55.9)	
<input type="checkbox"/> 47-MX10-3	<input type="checkbox"/> 47H-MX10-3		12 mm VFK	12 mm VFK		4.60 (116.8)	2.30 (58.4)	
<input type="checkbox"/> 47-MX12-3	<input type="checkbox"/> 47H-MX12-3							

Service Option Low-temperature Service

Trunnion ball valves for low-temperature service, with a temperature rating of -40°F to 200°F (-40°C to 93°C) are available. Low-temperature valves have low-temperature Buna C O-rings. All other materials and ratings are the same as those of standard valves. To order a valve for low-temperature service, add the suffix L to the end of the part number.
Example: SS47-FX4-P-L

47 Series Pressure - temperature Ratings

Material	316 SS		Alloy 400	
Seat Material	PCTFE PEEK	PTFE	PCTFE PEEK	PTFE
Temperature, °F (°C)	Working Pressure, psig (bar)			
-40 to 100 (-40 to 37)	6000 (414)	1500 (103)	5000 (345)	1500 (103)
100 to 200 (37 to 93)	See Pressure vs. Temperature			

47H Series Pressure - temperature Ratings

Material	316 SS				
End Connection	FN2, FN4 FX4, MX6	MX10	FX6 MX8	FX8	MX12
Temperature, °F (°C)	Working Pressure, psig (bar)				
-40 to 100 (-40 to 37)	10000 (690)	8400 (578)	7500 (516)	6700 (461)	6600 (454)
100 to 200 (37 to 93)	See Pressure vs. Temperature				

47 and 47H Series How to Order

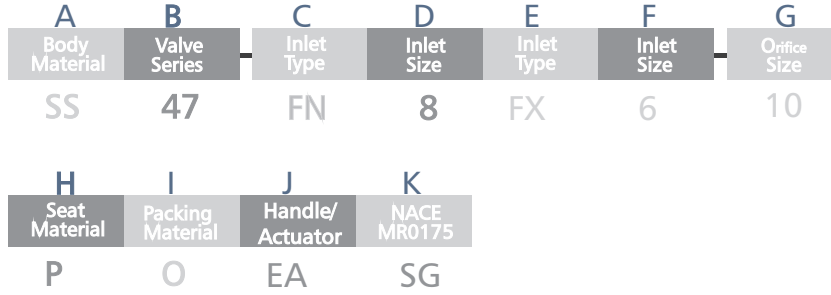

A	Body Material
SS:	316 SS
6L:	316L SS
S4:	304 SS
4L:	304L SS
S1:	321 SS
91:	F91
92:	F92
D5:	Duplex 2205
D7:	Duplex 2507
TI:	Titanium
A20:	Alloy 20
M:	Alloy 400
INC:	Alloy 600
HC:	Alloy C-276

B	Valve Series
47:	47 Series Ball Valves
47H:	47H Series Ball Valves

CE	Inlet/Outlet Type
FN	Female NPT
N	Male NPT
FR	Female BSPT
RT	Male BSPT
FM	Female ISO (for MRP)
MS	Male ISO (for MRG)
FP	Female BSPP (for RP)
BP	Male BSPP (for RG)
FX	Fractional Tube Fitting
MX	Metric Tube Fitting

DF	Inlet/Outlet Size
2	1/8"
4	1/4"
6	3/8" or 6 mm
8	1/2" or 8 mm
10	10 mm
12	3/4" or 12 mm

H	Seat Material
Standard with Virgin PTFE	
K	PCTFE
P	PEEK

J	Handle/Actuator
Standard with Balck Nylon Handle	
PA	Pneumatic Actuator
EA	Electric Actuator

I	Working Temperature
Normal Temperature	
L	Low Temperature (as low as -40°F)

I	Flow Pattern
Standard is 2-Way	
3	3-Way

K	NACE MR0175
Standard with no NACE applicable	
SG	With NACE MR0175

Remark:

- Standard thread pitch for metric threads are as follows:
 - M10 and below: 1 mm
 - M12 to M24: 1.5 mm
 - M27 and above: 2 mm
 Standard thread pitch should be ignored in the ordering number, others should be specified.

3-Piece Thread-loaded Seat Patent Design Ball Valves

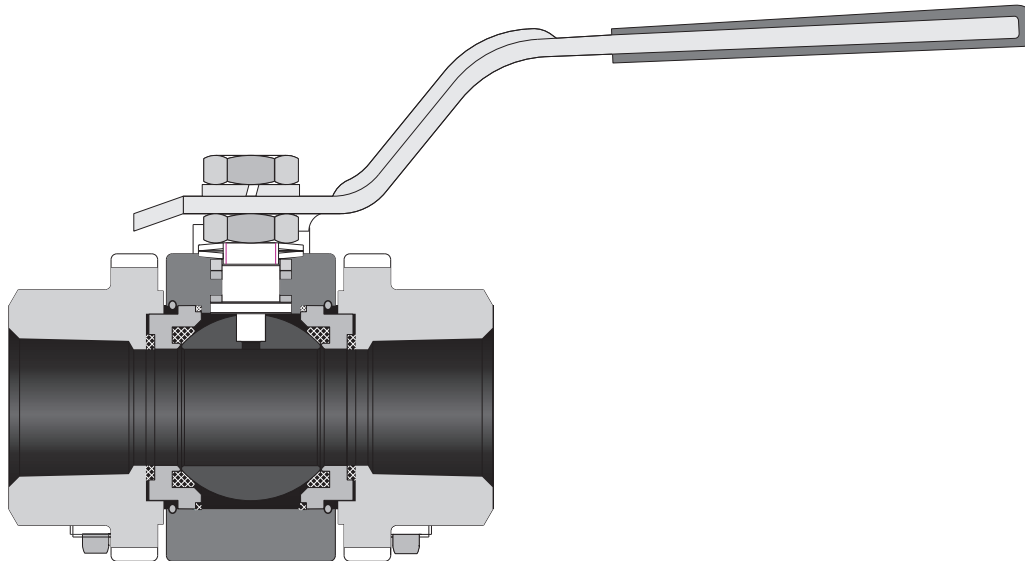

44 Series

- 44 series ball valves stem springs compensate for changes in pressure and temperature, and wear.
- High-strength stem bearings provide smooth actuation, eliminate galling between valve stem and body, resist wear.
- Bottom-loaded stem prevents stem blowout and enhances system safety.
- Quarter-turn actuation.
- Wide selection of seat materials.
- Optional vent porting.
- Stainless steel, carbon steel, brass, and special alloys.
- Variety of end connections in 1/8 to 2 in . and 6 to 25 mm sizes.
- Pneumatic and electric actuators are available.
- Pressures up to 3000 psig (207 bar).
- Patent-pending two thread-loaded seat design.
- Suitable for sour gas service; materials are selected in accordance with NACE MR0175/ISO 15156.
- Every valve is 100% factory tested with nitrogen.

Pressure vs. Temperature

Virgin PTFE Seat
Temperature (°C)

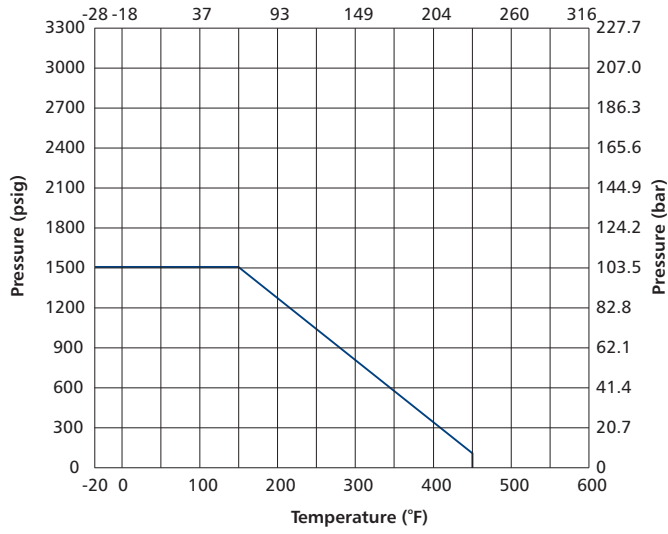

Reinforced PTFE Seat
Temperature (°C)

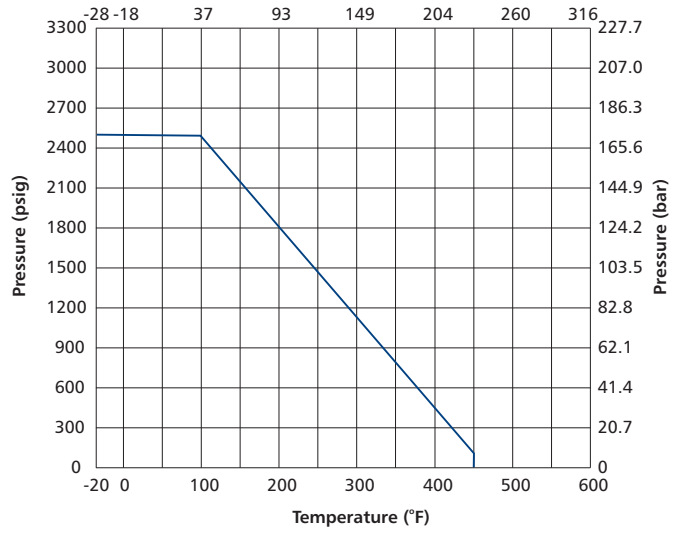

UHMWPE Seat
Temperature (°C)

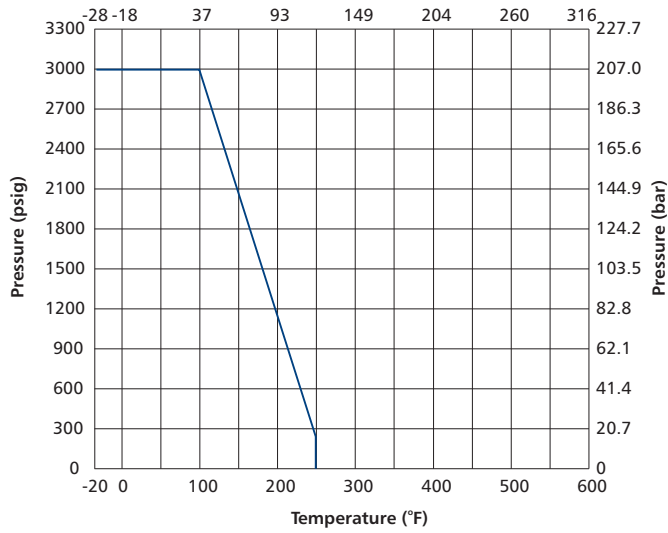

PEEK Seat
Temperature (°C)

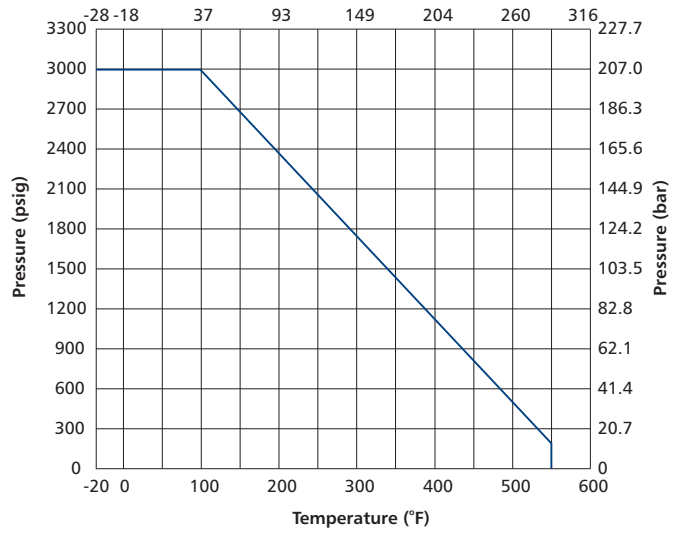

Standard Materials of Construction

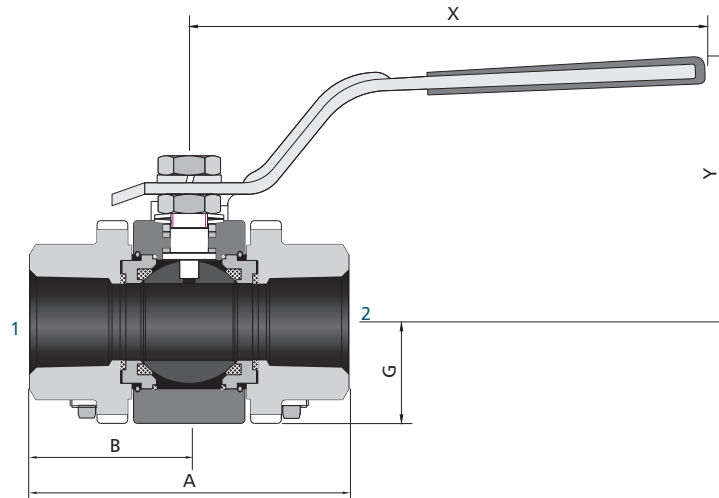

Item	Component	Valve Body Material			
		CF8M/ A351	CF3M/ A351	CF8/ A351	CF3/ A351
1	Stem Nut	Gr. 8M/A194			
2	Handle	CF8/A351 (with vinyl sleeve)			
3	Grounding Spring	304 SS/A313			
4	Gland	316 SS/A276 or 304 SS/A276			
5	Packing Support	316 SS/A276 or 304 SS/A276			
6	Top Packing	PTFE/D1710 or Reinforced PTFE or PEEK			
7	Bottom Packing	PTFE/D1710 or Reinforced PTFE or PEEK			
8	Body Bolt	Gr. B8M/A193			
9	Stem Spring	316 SS/A240			
10	Stem	316 SS/A276 or 316 SS/A479			
11	Stop Bolt	304 SS/A479			
12	Body	CF8M/A351	CF3M/A351	CF8/A351	CF3/A351
13	Ball	316 SS/A276 or 316 SS/A479			
14	Seat	PTFE/D1710 or Reinforced PTFE or PEEK or UHMWPE/D4020			
15	Coned-disc Spring	316 SS/A240			
16	Flange Seal	PTFE/D1710 or O-ring or Graphite			
17	Flange	CF8M/A351	CF3M/A351	CF8/A351	CF3/A351
18	Gasket	304 SS			
19	Nut	Gr. 8M/A194			
20	Handle Lock	304 SS/A240			
	Lubricants	Silicone-based and PTTE-based			

Other materials available upon request.

Dimensions

Basic Ordering Number	Connection Type and Size		Orifice in. (mm)	Cv	Dimension, in. (mm)							
	Connection 1	Connection 2/3			A	B	G	J	X	Y		
□□44-FX4-5	1/4" VFK	1/4" VFK	0.188 (4.8)	1.2	3.17 (80.5)	1.59 (40.4)	0.68 (17.3)	1.35 (34.3)	2.37 (60.2)	1.66 (42.2)		
□□44-MX6-5	6 mm VFK	6 mm VFK										
□□44-MX8-5	8 mm VFK	8 mm VFK										
□□44-TS4-5	1/4" TS	1/4" TS			2.16 (54.8)	1.08 (27.4)						
□□44-MTS6-5	3/8" MTS	3/8" MTS			2.08 (52.8)	1.04 (26.4)						
□□44-PB4-5	1/4 PB	1/4 PB										
□□44-FN2-7	1/8 Female NPT	1/8 Female NPT	0.281 (7.1)	3.8	2.16 (54.9)	1.08 (27.4)	0.68 (17.3)	1.35 (34.6)	2.37 (60.2)	1.66 (42.2)		
□□44-FR2-7	1/8 Female BSPT	1/8 Female BSPT										
□□44-FP2-7	1/8 Female BSPP	1/8 Female BSPP										
□□44-FN4-7	1/4 Female NPT	1/4 Female NPT										
□□44-FR4-7	1/4 Female BSPT	1/4 Female BSPT							2.31 (58.7)			
□□44-FP4-7	1/4 Female BSPP	1/4 Female BSPP										
□□44-FX5-7	5/16" VFK	5/16" VFK			3.17 (80.5)	1.59 (40.4)			2.37 (60.2)			
□□44-FX6-7	3/8" VFK	3/8" VFK										
□□44-MX10-7	10 mm VFK	10 mm VFK									3.20 (81.3)	1.60 (40.6)
□□44-TS6-7	3/8" TS	3/8" TS									2.16 (54.8)	1.08 (27.4)
□□44-PB6-7	3/8 PB	3/8 PB									2.08 (52.8)	1.04 (26.4)
□□44-FX8-10	1/2" VFK	1/2" VFK	0.406 (10.3)	7.5	4.04 (102.6)	2.02 (51.3)	0.89 (22.6)	1.78 (45.2)	4.50 (114.0)	2.35 (59.7)		
□□44-MX12-10	12 mm VFK	12 mm VFK	0.375 (9.5)									
□□44-TS8-10	1/2" TS	1/2" TS	0.411 (10.4)								2.70 (68.6)	1.34 (34.0)
□□44-FN6-10	3/8 Female NPT	3/8 Female NPT	0.516 (13.1)	12	2.70 (68.6)	1.35 (34.3)	0.89 (22.6)	1.78 (45.2)	4.50 (114.0)	2.35 (59.7)		
□□44-FR6-13	3/8 Female BSPT	3/8 Female BSPT										
□□44-FP6-13	3/8 Female BSPP	3/8 Female BSPP										
□□44-FN8-13	1/2 Female NPT	1/2 Female NPT										
□□44-FR8-13	1/2 Female BSPT	1/2 Female BSPT										
□□44-FP8-13	1/2 Female BSPP	1/2 Female BSPP										
□□44-FX12-13	3/4" VFK	3/4" VFK		13.6	4.04 (102.6)	2.02 (51.3)						
□□44-MX16-13	16 mm VFK	16 mm VFK										
□□44-MX18-13	18 mm VFK	18 mm VFK										
□□44-TS12-13	3/4" TS	3/4" TS		15	2.70 (68.6)	1.34 (34.0)						
□□44-PS8-13	1/2 PS	1/2 PS										
□□44-PB8-13	1/2 PB	1/2 PB	2.69 (68.3)	1.34 (34.0)								

Dimensions

Basic Ordering Number	Connection Type and Size		Orifice in. (mm)	Cv	Dimension, in. (mm)						
	Connection 1	Connection 2/3			A	B	G	J	X	Y	
□□44-PB12-13	3/4 PB	3/4 PB	0.516 (13.1)	13.6	2.69 (68.3)	1.34 (34.0)	0.89 (22.6)	1.78 (45.2)	4.50 (114.0)	2.35 (59.7)	
□□44-FN12-22	3/4 Female NPT	3/4 Female NPT	0.875 (22.2)	31.0	3.59 (91.2)	1.80 (45.7)	1.25 (31.8)	2.50 (63.5)	6.00 (152.0)	2.94 (74.7)	
□□44-FR12-22	3/4 Female BSPT	3/4 Female BSPT									
□□44-FP12-22	3/4 Female BSPP	3/4 Female BSPP									
□□44-FN16-22	1 Female NPT	1 Female NPT		38.0	4.45 (113.0)	2.23 (56.6)					
□□44-FR16-22	1 Female BSPT	1 Female BSPT									
□□44-FP16-22	1 Female BSPP	1 Female BSPP									
□□44-FX16-22	1" VFK	1" VFK		40.0	5.36 (136.0)	2.68 (68.0)					
□□44-FX20-22	1 1/4" VFK	1 1/4" VFK			6.34 (161.0)	3.17 (80.5)					
□□44-MX25-22	25 mm VFK	25 mm VFK		40.0	5.36 (136.0)	2.68 (68.0)					
□□44-MX28-22	28 mm VFK	28 mm VFK			6.14 (156.0)	3.07 (78.0)					
□□44-TS16-22	1" TS	1" TS			3.59 (91.2)	1.80 (45.7)					
□□44-MTS25-22	25 mm MTS	25 mm MTS		38.0	3.59 (91.2)	1.80 (45.7)					
□□44-PS12-22	3/4 PS	3/4 PS		36.0							
□□44-PS16-22	1 PS	1 PS		42.0							
□□44-PB12-22	3/4 PB	3/4 PB		36.0							1.25 (31.8)
□□44-PB16-22	1 PB	1 PB		40.0	3.46 (87.9)	1.73 (43.9)					1.53 (38.9)
□□44-TS20-29	1 1/4" TS	1 1/4" TS	80.0	4.39 (112.0)	2.19 (55.6)						
□□44-PB20-29	1 1/4 PB	1 1/4 PB		4.57 (116.0)	2.28 (57.9)						
□□44-FN20-32	1 1/4 Female NPT	1 1/4 Female NPT	1.25 (31.8)	100.0	4.39 (112.0)	2.19 (55.6)	1.53 (38.9)	3.06 (77.7)	9.14 (232.0)	4.03 (102.0)	
□□44-FN24-32	1 1/2 Female NPT	1 1/2 Female NPT									
□□44-TS24-32	1 1/2" TS	1 1/2" TS									
□□44-PS20-32	1 1/4 PS	1 1/4 PS		90.0	4.50 (114.3)	2.25 (57.2)					
□□44-PS24-32	1 1/2 PS	1 1/2 PS		100.0	4.57 (116.0)	2.28 (57.9)					
□□44-PB24-32	1 1/2 PB	1 1/2 PB			4.57 (116.0)	2.29 (58.0)					
□□44-FN32-38	2 Female NPT	2 Female NPT	1.5 (38.1)	130.0	4.94 (125.4)	2.47 (62.7)	1.74 (44.2)	3.47 (88.1)	9.14 (232.0)	4.16 (106.0)	
□□44-FR32-38	2 Female BSPT	2 Female BSPT									
□□44-TS32-38	2" TS	2" TS									
□□44-PS32-38	2 PS	2 PS					1.70 (43.2)	3.47 (86.6)			
□□44-PB32-38	2 PB	2 PB					5.09 (129.0)	2.55 (64.8)			1.74 (44.2)

44 Series How to Order

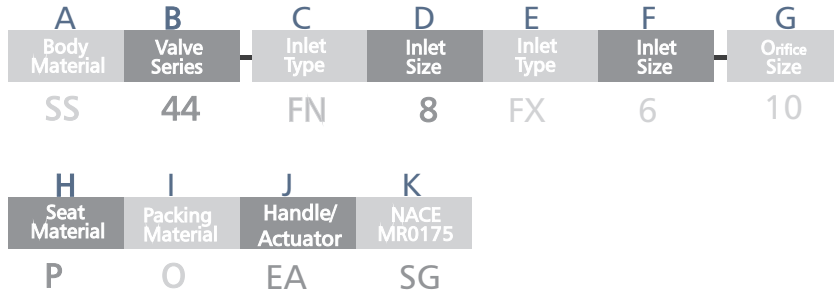

A	Body Material
SS:	316 SS
6L:	316L SS
S4:	304 SS
4L:	304L SS
S1:	321 SS
91:	F91
92:	F92
D5:	Duplex 2205
D7:	Duplex 2507
TI:	Titanium
A20:	Alloy 20
M:	Alloy 400
INC:	Alloy 600
HC:	Alloy C-276
B:	Brass
CS:	Carbon Steel

B	Valve Series
44:	44 Series Ball Valves

CE	Inlet/Outlet Type
FN	Female NPT
N	Male NPT
FR	Female BSPT
RT	Male BSPT
FM	Female ISO (for MRP)
MS	Male ISO (for MRG)
FP	Female BSPP (for RP)
BP	Male BSPP (for RG)
TS	Fractional Tube Socket Weld
MTS	Metric Tube Socket Weld
TB	Fractional Tube Butt Weld
MTB	Metric Tube Butt Weld
PS	Pipe Socket Weld
PB	Pipe Butt Weld
FX	Fractional Tube Fitting
MX	Metric Tube Fitting
UFB	Nut + Gasket + Fractional Bulge Nipple
UMB	Nut + Gasket + Metric Bulge Nipple

DF	Inlet/Outlet Size
2	1/8"
4	1/4"
6	3/8" or 6 mm
8	1/2" or 8 mm
10	10 mm
12	3/4" or 12 mm
14	14 mm or M14 x 1.5
16	1" or 16 mm
18	18 mm
20	1 1/4" or 20 mm or M20 x 1.5
22	22 mm or M22 x 1.5
24	M24 x 1.5
25	25 mm
27	M27 x 2
28	28 mm
32	2" or 32 mm

G	Orifice Size
5:	0.19" (4.8 mm)
7:	0.28" (7.1 mm)
10:	0.41" (10.4 mm)
13:	0.52" (13.1 mm)
22:	0.88" (22.2 mm)
29:	1.13" (28.6 mm)
32:	1.25" (31.8 mm)
38:	1.5" (38.1 mm)

H	Seat Material
Standard with Virgin PTFE	
R	Reinforced PTFE
P	PEEK

I	Packing Material
Standard with Reinforced PTFE	
G	Graphite
O	O-Ring

J	Handle/Actuator
Standard with Balck Nylon Handle	
PA	Pneumatic Actuator
EA	Electric Actuator

K	NACE MR0175
Standard with no NACE applicable	
SG	With NACE MR0175

Remark:

- Standard thread pitch for metric threads are as follows:
 M10 and below: 1 mm
 M12 to M20: 1.5 mm
 Standard thread pitch should be ignored in the ordering number, others should be specified.

3-piece General Pressure Ball Valves

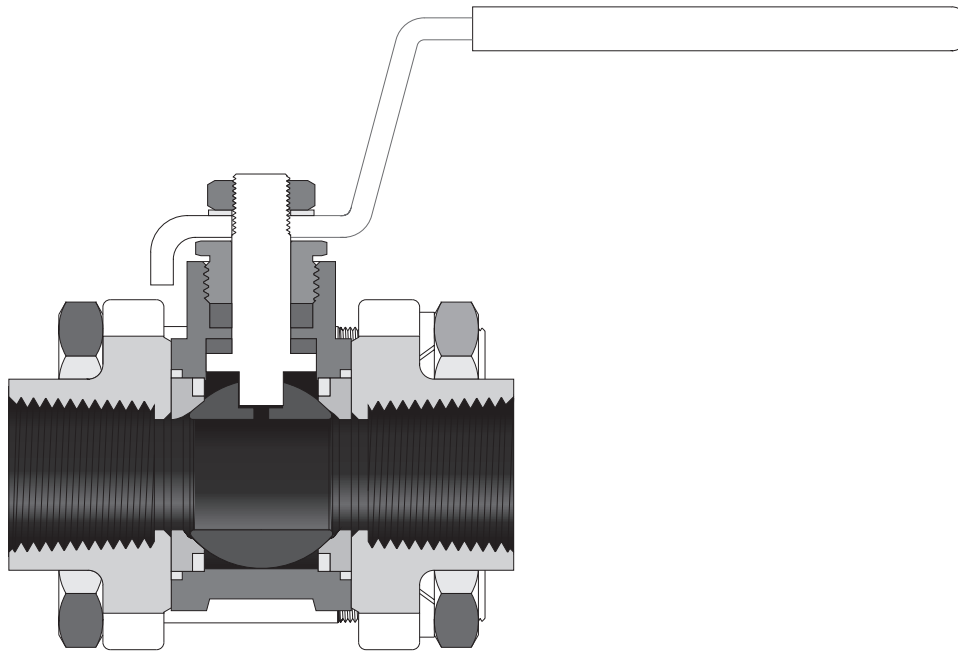

45 Series

- 45 series ball valves are for use in 3-piece casting valve body.
- Free floating ball design allows for seat wear compensation. Ultra low internal volume.
- Self-compensating stem seal.
- Blow out resistant stem.
- Fully enclosed body bolting.
- Four bolt construction.
- Pneumatic and electric actuation options.
- Stainless steel and other alloy steel body materials can be selected.
- 45 series standard pressures up to 1000 psig (68.9 bar).
- Temperatures up to 450° F (232° C) with PTFE packing;
- End connections:
 - 1/8" to 3" thread
 - 1/8" to 3" pipe butt or socket weld
 - 1/2" to 2" and 12 mm to 50 mm tube butt or socket weld
 - 1/2" to 2" and 12 mm to 50 mm tube butt or socket weld
 - 1/2" to 2" and 12 mm to 38 mm tube fitting
 - 1/2" to 4" flange
- Orifice sizes: 4.8 mm to 76 mm
- Suitable for sour gas service; materials are selected in accordance with NACE MR0175/ISO 15156.
- Every valve is 100% factory tested with nitrogen.

Pressure vs. Temperature

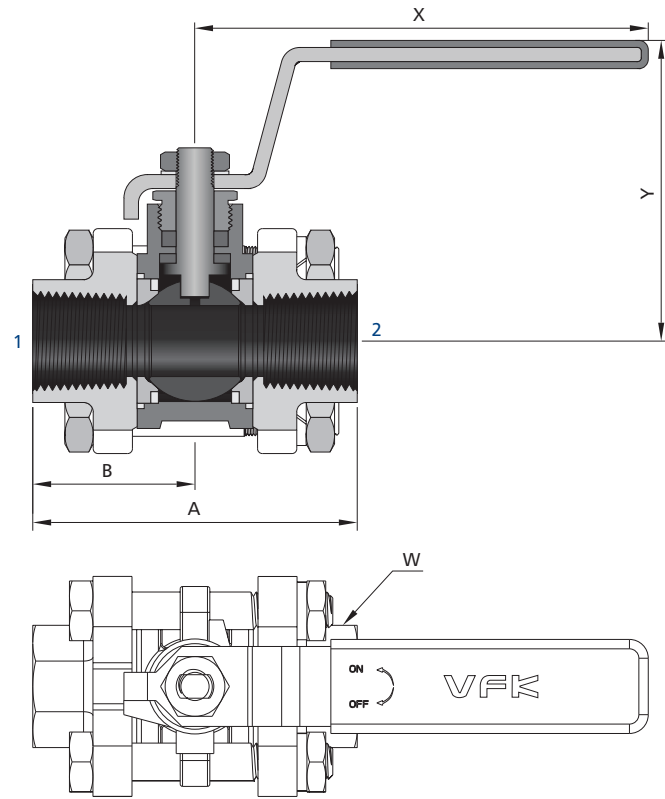
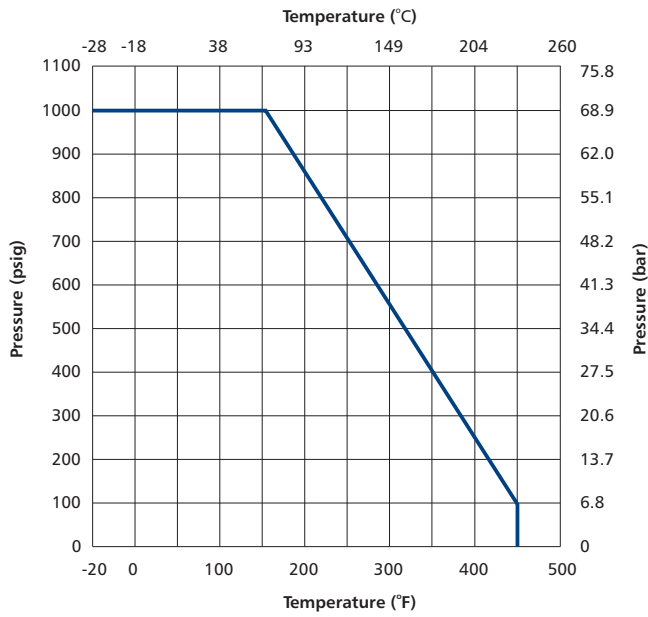

Standard Materials of Construction

Item	Component	Valve Body Material			
		CF8M/A351	CF3M/A351	CF8/A351	CF3/A351
1	Stem Nut	Gr. 8M/A194			
2	Gasket	304 SS			
3	Handle	CF8/A351 (with vinyl sleeve)			
4	Gland	316 SS/A276 or 304 SS/A276			
5	Stem Packing	PTFE/D1710			
6	Stem	316 SS/A276			
7	Stem Bearing	PTFE/D1710			
8	Body	CF8M/A351	CF3M/A351	CF8/A351	CF3/A351
9	Body Bolt	Gr. B8M/A193			
10	Ball	316 SS/A276			
11	Support Ring	316 SS/A276			
12	Seat	PTFE/D1710			
13	Flange Seal	PTFE/D1710			
14	Flange	CF8M/A351	CF3M/A351	CF8/A351	CF3/A351
15	Gasket	304 SS			
16	Nut	Gr. 8M/A194			
Lubricants		Silicone-based and PTFE-based			

Dimensions

Basic Ordering Number	Connection Type and Size		Orifice in. (mm)	Cv	Dimension, in. (mm)				
	Connection 1	Connection 2			A	B	W	X	Y
□□45-FN2-5	1/8 Female NPT	1/8 Female NPT	0.188 (4.8)	1.2	2.57 (65.2)	1.28 (32.6)			
□□45-FP2-5	1/8 Female BSPP	1/8 Female BSPP							
□□45-PB4-5	1/4 PB	1/4 PB							
□□45-FX4-5	1/4" VFK	1/4" VFK							
□□45-MX6-5	6 mm VFK	6 mm VFK							
□□45-MX8-5	8 mm VFK	8 mm VFK							
□□45-FN4-7	1/4 Female NPT	1/4 Female NPT	0.281 (7.1)	3.8	2.57 (65.2)	1.28 (32.6)	0.93 (23.5)	3.94 (100.0)	2.15 (54.7)
□□45-FP4-7	1/4 Female BSPP	1/4 Female BSPP							
□□45-PS4-7	1/4 PS	1/4 PS							
□□45-PB6-7	3/8 PB	3/8 PB							
□□45-FX6-7	3/8" VFK	3/8" VFK							
□□45-MX10-7	10 mm VFK	10 mm VFK							
□□45-FX8-11	1/2" VFK	1/2" VFK	0.417 (10.6)	7.5	4.04 (103.0)	2.02 (51.3)			
□□45-MX12-11	12 mm VFK	12 mm VFK							
□□45-MX14-11	14 mm VFK	14 mm VFK							
□□45-FN6-13	3/8 Female NPT	3/8 Female NPT	0.50 (12.7)	11.3	2.57 (65.2)	1.28 (32.6)	0.88 (22.3)	3.94 (100.0)	2.26 (57.5)
□□45-FP6-13	3/8 Female BSPP	3/8 Female BSPP							
□□45-PS6-13	3/8 PS	3/8 PS							
□□45-PB8-13	1/2 PB	1/2 PB							
□□45-FX10-13	5/8" VFK	5/8" VFK							
□□45-MX16-13	16 mm VFK	16 mm VFK							
□□45-FN8-15	1/2 Female NPT	1/2 Female NPT	0.591 (15.0)	13.0	2.74 (69.5)	1.37 (34.8)	1.06 (27.0)		
□□45-FP8-15	1/2 Female BSPP	1/2 Female BSPP							
□□45-PS8-15	1/2 PS	1/2 PS							
□□45-MTB22-15	22 mm MTB	22 mm MTB							
□□45-TS12-15	3/4" TS	3/4" TS							
□□45-MTS18-15	18 mm MTS	18 mm MTS							
□□45-FX12-15	3/4" VFK	3/4" VFK							
□□45-MX18-15	18 mm VFK	18 mm VFK							
□□45-MX20-15	20 mm VFK	20 mm VFK							
□□45-FN12-20	3/4 Female NPT	3/4 Female NPT	0.787 (20.0)	50.0	3.15 (80.0)	1.57 (40.0)	1.34 (34.0)	5.08 (129.0)	2.48 (63.0)
□□45-FP12-20	3/4 Female BSPP	3/4 Female BSPP							

Dimensions

Basic Ordering Number	Connection Type and Size		Orifice in. (mm)	Cv	Dimension, in. (mm)						
	Connection 1	Connection 2			A	B	W	X	Y		
□□45-PB12-20	3/4 PB	3/4 PB	0.787 (20.0)	50.0	3.15 (80.0)	1.57 (40.0)	1.34 (34.0)	5.08 (129.0)	2.48 (63.0)		
□□45-PS12-20	3/4 PS	3/4 PS									
□□45-TS16-20	1" TS	1" TS									
□□45-MTB25-20	25 mm MTB	25 mm MTB			0.984 (25.0)	93.0	5.36 (136.0)	2.68 (68.1)	1.63 (41.3)	6.14 (156.0)	2.97 (75.5)
□□45-MTS25-20	25 mm MTS	25 mm MTS									
□□45-FX16-20	1" VFK	1" VFK									
□□45-MX22-20	22 mm VFK	22 mm VFK									
□□45-MX25-20	25 mm VFK	25 mm VFK									
□□45-MX28-20	28 mm VFK	28 mm VFK			1.260 (32.0)	110.0	7.59 (193.0)	3.79 (96.3)	1.94 (49.2)	6.14 (156.0)	3.19 (81.0)
□□45-FN16-25	1 Female NPT	1 Female NPT									
□□45-FP16-25	1 Female BSPP	1 Female BSPP									
□□45-PS16-25	1 PS	1 PS	1.50 (38.0)	130.0	4.33 (110.0)	2.17 (55.0)	2.24 (57.0)	7.19 (182.5)	3.70 (94.0)		
□□45-PB16-25	1 PB	1 PB									
□□45-FX20-25	1 1/4" VFK	1 1/4" VFK									
□□45-FN20-32	1 1/4 Female NPT	1 1/4 Female NPT	1.97 (50.0)	270.0	5.51 (140.0)	2.75 (70.0)	2.76 (70.0)	7.19 (182.5)	4.11 (104.5)		
□□45-FP20-32	1 1/4 Female BSPP	1 1/4 Female BSPP									
□□45-PB20-32	1 1/4 PB	1 1/4 PB									
□□45-FN24-38	1 1/2 Female NPT	1 1/2 Female NPT	2.50 (63.5)	350.0	7.28 (185.0)	3.64 (92.5)	3.39 (86.0)	9.92 (252.0)	5.16 (131.0)		
□□45-FP24-38	1 1/2 Female BSPP	1 1/2 Female BSPP									
□□45-PB24-38	1 1/2 PB	1 1/2 PB									
□□45-FN32-50	2 Female NPT	2 Female NPT	2.99 (76.0)	500.0	8.07 (205.0)	4.04 (102.5)	3.98 (101.0)	9.92 (252.0)	5.47 (139.0)		
□□45-FP32-50	2 Female BSPP	2 Female BSPP									
□□45-PB32-50	2 PB	2 PB									
□□45-FN40-64	2 1/2 Female NPT	2 1/2 Female NPT	8.66 (220.0)	500.0	8.66 (220.0)	4.33 (110.0)	3.98 (101.0)	9.92 (252.0)	5.47 (139.0)		
□□45-FP40-64	2 1/2 Female BSPP	2 1/2 Female BSPP									
□□45-PB40-64	2 1/2 PB	2 1/2 PB									
□□45-FN48-76	3 Female NPT	3 Female NPT	8.66 (220.0)	500.0	8.66 (220.0)	4.33 (110.0)	3.98 (101.0)	9.92 (252.0)	5.47 (139.0)		
□□45-FP48-76	3 Female BSPP	3 Female BSPP									
□□45-PB48-76	3 PB	3 PB									

45 Series How to Order

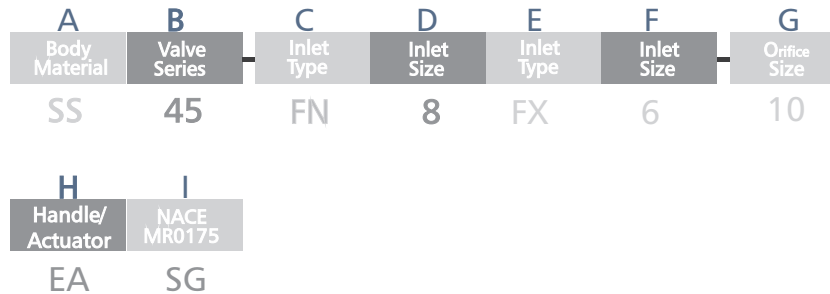

A	Body Material
SS:	316 SS
6L:	316L SS
S4:	304 SS
4L:	304L SS
S1:	321 SS
91:	F91
92:	F92
D5:	Duplex 2205
D7:	Duplex 2507
TI:	Titanium
A20:	Alloy 20
M:	Alloy 400
INC:	Alloy 600
HC:	Alloy C-276
CS:	Carbon Steel

B	Valve Series
45:	45 Series Ball Valves

CE	Inlet/Outlet Type
FN	Female NPT
N	Male NPT
FR	Female BSPT
RT	Male BSPT
FM	Female ISO (for MRP)
MS	Male ISO (for MRG)
FP	Female BSPP (for RP)
BP	Male BSPP (for RG)
TS	Fractional Tube Socket Weld
MTS	Metric Tube Socket Weld
TB	Fractional Tube Butt Weld
MTB	Metric Tube Butt Weld
PS	Pipe Socket Weld
PB	Pipe Butt Weld
FX	Fractional Tube Fitting
MX	Metric Tube Fitting

DF	Inlet/Outlet Size
2	1/8"
4	1/4"
6	3/8" or 6 mm
8	1/2" or 8 mm
10	10 mm
12	3/4" or 12 mm
14	14 mm or M14 x 1.5
16	1" or 16 mm
18	18 mm
20	1 1/4" or 20 mm or M20 x 1.5
22	22 mm or M22 x 1.5
24	M24 x 1.5
25	25 mm
27	M27 x 2
28	28 mm
32	2" or 32 mm
36	2 1/4" or M36 x 2 mm
40	2 1/2" or M40 x 2 mm
48	3" or M48 x 2 mm

G	Orifice Size
5:	0.19" (4.8 mm)
7:	0.28" (7.1 mm)
10:	0.41" (10.4 mm)
15:	0.59" (15.0 mm)
20:	0.79" (20.0 mm)
25:	0.98" (25.0 mm)
32:	1.26" (32.0 mm)
38:	1.5" (38.1 mm)
50:	2" (50.8 mm)
64:	2.5" (63.5 mm)
76:	3" (76 mm)

H Handle/Actuator

Standard with Balck Nylon Handle

PA	Pneumatic Actuator
EA	Electric Actuator

I NACE MR0175

Standard with no NACE applicable

SG	With NACE MR0175
----	------------------

Remark:

- Standard thread pitch for metric threads are as follows:
 M10 and below: 1 mm
 M12 to M20: 1.5 mm
 Standard thread pitch should be ignored in the ordering number, others should be specified.

Bar Stock Ball Valves

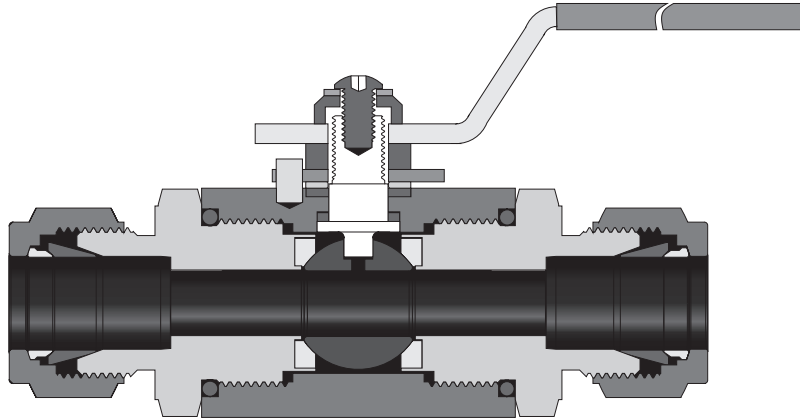

42 Series

- Blowout proof design with internally loaded stem.
- Handle indicates the flow direction.
- Positive stop with a robust stop pin.
- High flow rate with maximum orifice.
- Various flow control with side and bottom inlet port on 3-way diverter valves.
- Valves are designed to control fluids in full open or full closed position.
- Valves that have not been actuated for a period of time may have a higher initial actuation torque.
- Valves must be in open position during system test not to damage the valve seat.
- Optional pneumatic and electric actuator.
- Standard maximum pressures:
Stainless steel: 6000 psig (413 bar).
High pressure up to 10 000 psig (689 bar).
- Temperatures up to 450°F (232°C);
- Suitable for sour gas service; materials are selected in accordance with NACE MR0175/ISO 15156.
- Every valve is 100% factory tested with nitrogen.

Pressure vs. Temperature

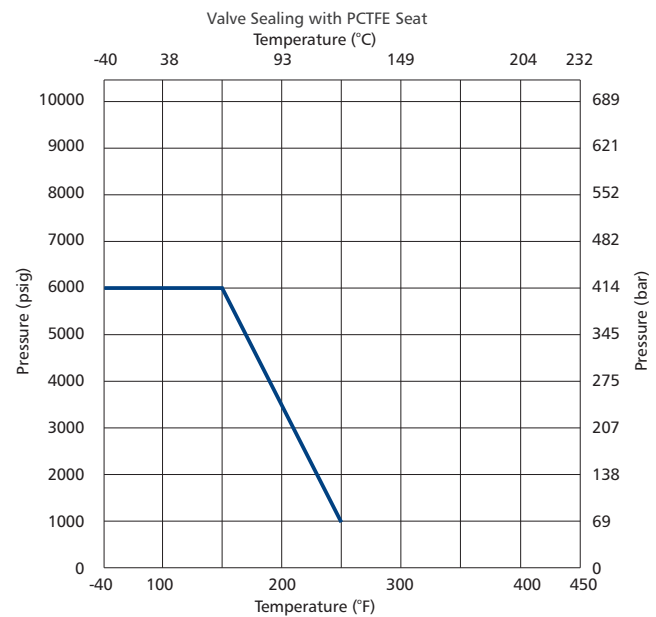
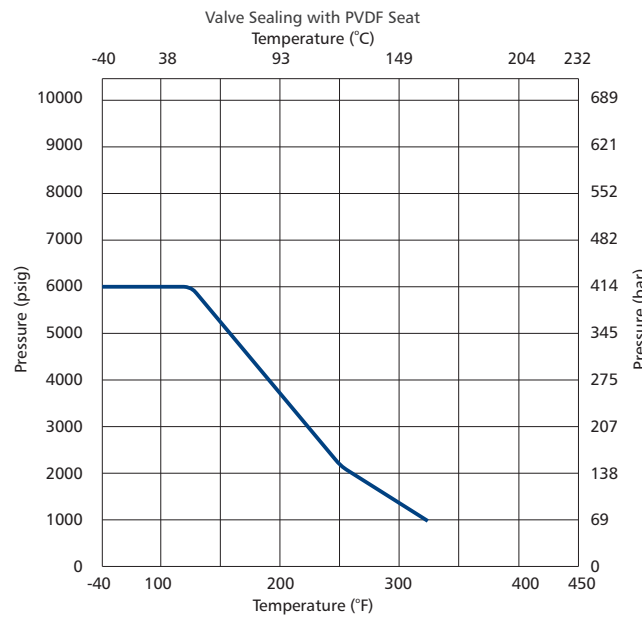
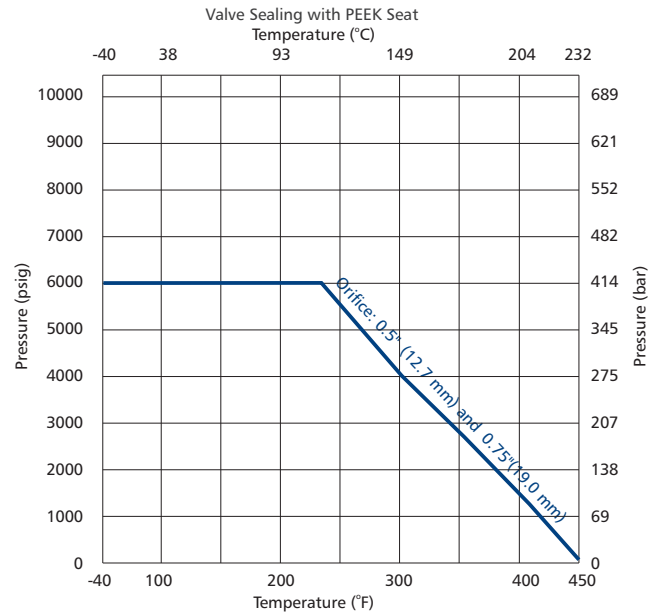
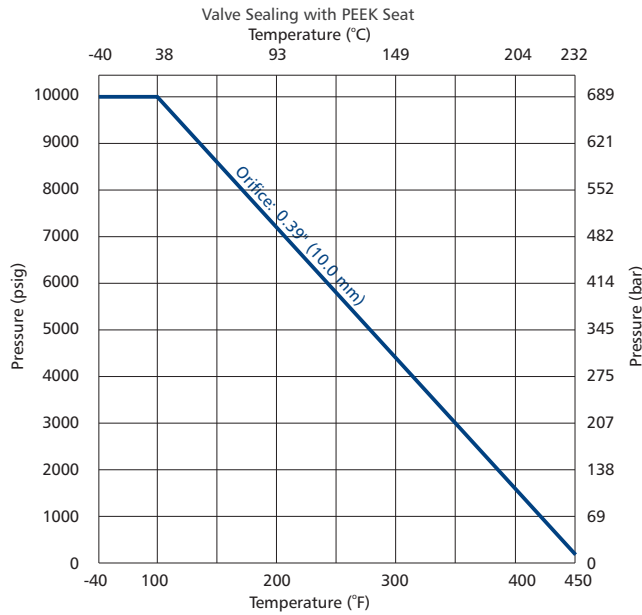

Temperature Ranges

Packing Materials	Temperature Range °F (°C)
PTFE	-40 to 450 (-40 to 232)
Buna-N	-40 to 250 (-40 to 121)
Fluorocarbon FKM	-10 to 400 (-23 to 204)
Neoprene	-40 to 250 (-40 to 121)

Standard Materials of Construction

2-way Valves

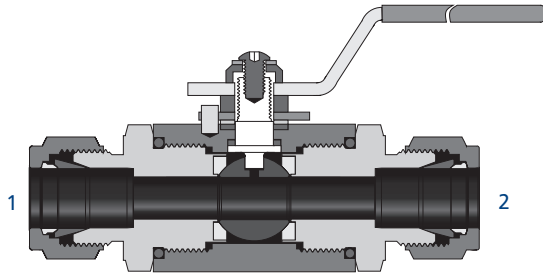

3-way Valves

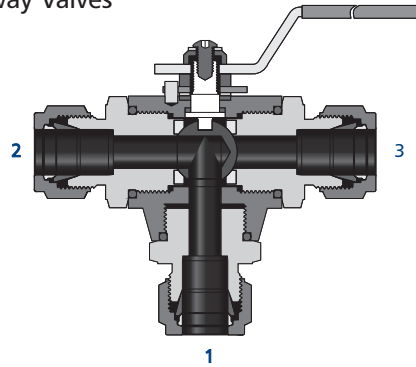

Item	Component	Body Material	
		316 SS	Alloy 400
1	End Connector	316 SS/A276	Alloy 400/B164
2	Stop Pin	Stainless steel	
3	Spring Washer	316 SS/A276	
4	Bolt	Stainless steel	
5	Cover	316 SS/A276	
6	Stem	316 SS/A276	
7	Handle	Stainless steel with vinyl cover	
8	Stem Nut	Stainless steel	
9	Stop Block	316 SS/A240	
10	Stem Washer	316 SS/A276	
11	Stem Packing	PTFE or fluorocarbon FKM or neoprene or buna N	
12	Body	316 SS/A479	Alloy 400/B164
13	Seat	PVDF or PCTFE or PEEK	
14	Ball	316 SS/A479	Alloy R- 405/B164
15	End Seal	PTFE or fluorocarbon FKM or neoprene or buna N	

Dimensions

2-way Valves

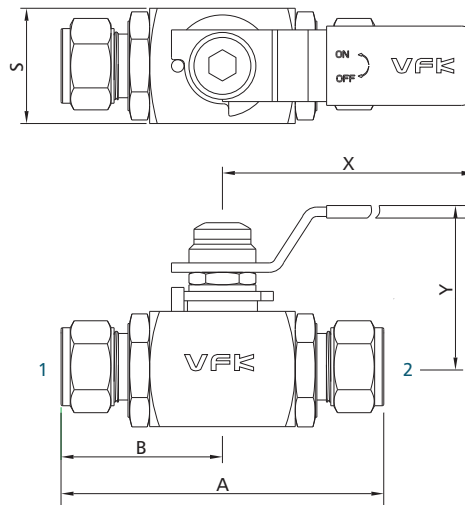

Dimensions

Basic Ordering Number	Connection Type and Size		Orifice in. (mm)	Cv	Dimension, in. (mm)				
	Connection 1	Connection 2			A	B	X	Y	S
□□42-MX6-10	6 mm VFK	6 mm VFK	0.39 (10.0)	1.2	3.54 (90.0)	1.77 (45.0)	5.12 (130.0)	1.73 (44.0)	1.30 (32.0)
□□42-MX8-10	8 mm VFK	8 mm VFK			3.60 (91.6)	1.80 (45.8)			
□□42-MX10-10	10 mm VFK	10 mm VFK		3.7	3.70 (94.0)	1.85 (47.0)			
□□42-MX12-10	12 mm VFK	12 mm VFK		7.5	4.33 (110.0)	2.16 (55.0)			
□□42-MX14-10	14 mm VFK	14 mm VFK							
□□42-FX4-10	1/4" VFK	1/4" VFK		1.2	3.78 (96.0)	1.89 (48.0)			
□□42-FX6-10	3/8" VFK	3/8" VFK		3.7	4.04 (102.5)	2.02 (51.3)			
□□42-FX8-10	1/2" VFK	1/2" VFK							
□□42-FN4-10	1/4 Female NPT	1/4 Female NPT		7.5	2.91 (74.0)	1.45 (37.0)			
□□42-FN6-10	3/8 Female NPT	3/8 Female NPT							
□□42-FN8-10	1/2 Female NPT	1/2 Female NPT							
□□42-N4-10	1/4 Male NPT	1/4 Male NPT		3.7	3.76 (95.4)	1.88 (47.6)			
□□42-N6-10	3/8 Male NPT	3/8 Male NPT		7.5	3.94 (100.2)	1.97 (50.1)			
□□42-N8-10	1/2 Male NPT	1/2 Male NPT							
□□42-MX16-13	16 mm VFK	16 mm VFK		0.5 (12.7)	10.0	4.56 (116.0)			
□□42-MX18-13	18 mm VFK	18 mm VFK	4.12 (104.6)			2.06 (52.3)			
□□42-MX20-13	20 mm VFK	20 mm VFK	4.43 (112.6)			2.22 (56.3)			
□□42-MX22-13	22 mm VFK	22 mm VFK							
□□42-FX10-13	5/8" VFK	5/8" VFK	4.56 (116.0)			2.28 (58.0)			
□□42-FX12-13	3/4" VFK	3/4" VFK	4.52 (115.0)			2.26 (57.5)			
□□42-FN8-13	1/2 Female NPT	1/2 Female NPT	3.50 (89.0)			1.75 (44.5)			
□□42-FN12-13	3/4 Female NPT	3/4 Female NPT	3.54 (90.0)			1.77 (45.0)			
□□42-N12-13	3/4 Male NPT	3/4 Male NPT	4.14 (105.2)			2.07 (52.6)			
□□42-MX20-19	20 mm VFK	20 mm VFK	0.71 (18.0)	19.0	4.87 (123.8)	2.43 (61.9)	6.30 (160.0)	2.08 (53.0)	1.96 (50.0)
□□42-MX22-19	22 mm VFK	22 mm VFK		30.0	5.11 (129.8)	2.66 (64.9)			
□□42-MX25-19	25 mm VFK	25 mm VFK							
□□42-FX12-19	3/4" VFK	3/4" VFK		19.0	4.92 (125.0)	2.46 (62.5)			
□□42-FX16-19	1" VFK	1" VFK		30.0	5.27 (134.0)	2.63 (67.0)			
□□42-FN12-19	3/4 Female NPT	3/4 Female NPT			4.25 (108.0)	2.12 (54.0)			
□□42-FN16-19	1 Female NPT	1 Female NPT			5.00 (127.0)	2.50 (63.5)			
□□42-N12-19	3/4 Male NPT	3/4 Male NPT		19.0	4.68 (119.0)	2.34 (59.5)			
□□42-N16-19	1 Male NPT	1 Male NPT		30.0	5.07 (129.0)	2.53 (64.5)			
□□42-FN16-25	1 Female NPT	1 Female NPT	0.98 (25.0)	Full Bore	4.44 (112.9)	2.22 (56.4)			

2-way Torque for Turning Handle lbf-in (N·m)

Orifice in. (mm)	Working Pressure, psig (bar)							
	0 (0)	1000 (69)	2000 (138)	3000 (207)	6000 (414)	7000 (482)	8000 (552)	10000 (690)
0.39 (10.0)	14 (1.6)	17 (2.0)	17 (2.0)	22 (2.5)	35 (4.0)	40 (4.5)	44 (5.0)	44 (5.0)
0.50 (12.7)	28 (3.2)	31 (3.5)	34 (3.8)	35 (4.0)	35 (4.0)	—	—	—
0.75 (19.0)	31 (3.5)	32 (3.6)	34 (3.8)	37 (4.2)	40 (4.5)	—	—	—

Valve that have not been actuated for a period of time may have a higher initial actuation torque.

3-way Valves

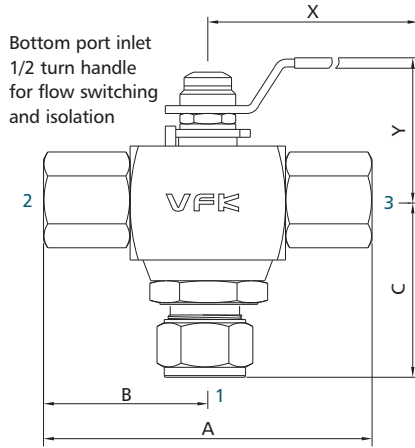

Vertical Pattern

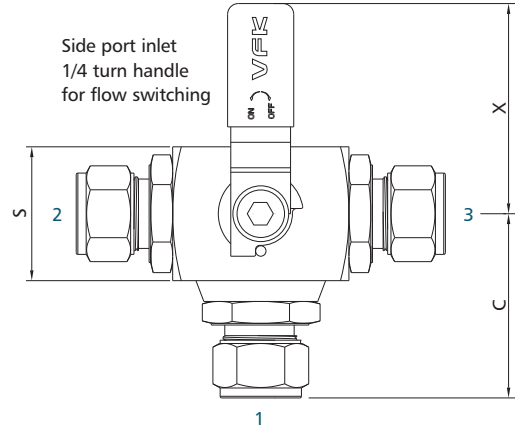

Horizontal Pattern

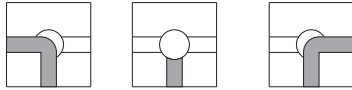

Isolation

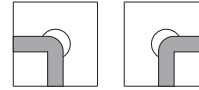

Basic Ordering Number	Connection Type and Size		Orifice in. (mm)	Cv	Dimension, in. (mm)					
	Connection 1	Connection 2/3			A	B	C	X	Y	S
□□42-MX6-V10	6 mm VFK	6 mm VFK	0.39 (10.0)	1.2	3.54 (90.0)	1.77 (45.0)	2.00 (51.0)	5.12 (130.0)	1.73 (44.0)	1.30 (32.0)
□□42-MX8-V10	8 mm VFK	8 mm VFK			3.60 (91.6)	1.80 (45.8)	2.02 (51.3)			
□□42-MX10-V10	10 mm VFK	10 mm VFK			3.70 (94.0)	1.85 (47.0)	2.07 (52.5)			
□□42-MX12-V10	12 mm VFK	12 mm VFK		7.5	3.94 (100.0)	1.97 (50.0)	2.18 (55.5)			
□□42-MX14-V10	14 mm VFK	14 mm VFK			4.24 (107.6)	2.12 (53.8)	2.13 (54.0)			
□□42-FX4-V10	1/4" VFK	1/4" VFK		1.2	3.78 (96.0)	1.89 (48.0)	2.01 (53.3)			
□□42-FX6-V10	3/8" VFK	3/8" VFK		3.7	4.04 (102.5)	2.02 (51.2)	2.16 (54.8)			
□□42-FX8-V10	1/2" VFK	1/2" VFK		7.5	4.24 (107.6)	2.12 (53.8)	2.13 (54.0)			
□□42-FN4-V10	1/4 Female NPT	1/4 Female NPT			2.91 (74.0)	1.45 (37.0)	1.44 (36.5)			
□□42-FN6-V10	3/8 Female NPT	3/8 Female NPT			3.03 (77.0)	1.51 (38.5)	1.57 (40.0)			
□□42-FN8-V10	1/2 Female NPT	1/2 Female NPT		3.35 (85.0)	1.67 (42.5)	1.73 (44.0)				
□□42-N4-V10	1/4 Male NPT	1/4 Male NPT		3.7	3.36 (85.4)	1.68 (42.7)	1.90 (48.2)			
□□42-N6-V10	3/8 Male NPT	3/8 Male NPT			7.5	3.75 (95.2)	1.88 (47.6)			
□□42-N8-V10	1/2 Male NPT	1/2 Male NPT								

Basic Ordering Number	Connection Type and Size		Orifice in. (mm)	Cv	Dimension, in. (mm)						
	Connection 1	Connection 2/3			A	B	C	X	Y	S	
□□42-MX16-V13	16 mm VFK	16 mm VFK	0.5 (12.7)	10.0	4.04 (102.6)	2.02 (51.3)	2.41 (61.3)	5.71 (145.0)	1.89 (48.0)	1.50 (38.0)	
□□42-MX18-V13	18 mm VFK	18 mm VFK			4.12 (104.6)	2.06 (52.3)	2.45 (62.3)				
□□42-MX20-V13	20 mm VFK	20 mm VFK			4.43 (112.6)	2.22 (56.3)	2.61 (66.3)				
□□42-MX22-V13	22 mm VFK	22 mm VFK			4.50 (114.4)	2.25 (57.2)	2.57 (65.3)				
□□42-FX10-V13	5/8" VFK	5/8" VFK			4.52 (115.0)	2.26 (57.5)	2.57 (65.3)				
□□42-FX12-V13	3/4" VFK	3/4" VFK			3.50 (89.0)	1.75 (44.5)	1.95 (49.5)				
□□42-FN8-V13	1/2 Female NPT	1/2 Female NPT			3.54 (90.0)	1.77 (45.0)	2.16 (55.0)				
□□42-FN12-V13	3/4 Female NPT	3/4 Female NPT			4.14 (105.2)	2.07 (52.6)	2.46 (62.6)				
□□42-N12-V13	3/4 Male NPT	3/4 Male NPT									
□□42-MX20-V19	20 mm VFK	20 mm VFK	0.71 (18.0)	19.0	4.87 (123.8)	2.43 (61.9)	2.89 (73.4)	6.30 (160.0)	2.08 (53.0)	1.96 (50.0)	
□□42-MX22-V19	22 mm VFK	22 mm VFK			5.11 (129.8)	2.66 (64.9)	3.00 (76.2)				
□□42-MX25-V19	25 mm VFK	25 mm VFK			19.0	4.59 (116.6)	2.29 (58.3)				2.75 (69.8)
□□42-FX12-V19	3/4" VFK	3/4" VFK			30.0	5.11 (129.8)	2.66 (64.9)				2.85 (72.4)
□□42-FX16-V19	1" VFK	1" VFK			30.0	3.78 (96.0)	1.89 (48.0)				2.22 (56.5)
□□42-FN12-V19	3/4 Female NPT	3/4 Female NPT			30.0	4.37 (111.0)	2.18 (55.5)				2.40 (60.8)
□□42-FN16-V19	1 Female NPT	1 Female NPT			19.0	4.54 (115.2)	2.27 (57.6)				2.72 (69.1)
□□42-N12-V19	3/4 Male NPT	3/4 Male NPT			30.0	4.91 (124.8)	2.45 (62.4)				2.90 (73.9)
□□42-N16-V19	1 Male NPT	1 Male NPT									

3-way Torque for Turning Handle lbf·in (N·m)

Orifice in. (mm)	Working Pressure, psig (bar)							
	0 (0)	1000 (69)	2000 (138)	3000 (207)	6000 (414)	7000 (482)	8000 (552)	10000 (690)
0.39 (10.0)	14 (1.6)	13 (1.5)	13 (1.5)	11 (1.2)	9 (1.0)	7 (0.8)	7 (0.8)	5 (0.6)
0.50 (12.7)	28 (3.2)	28 (3.2)	26 (3.0)	22 (2.5)	17 (1.9)	—	—	—
0.75 (19.0)	31 (3.5)	29 (3.3)	26 (3.0)	25 (2.8)	18 (2.0)	—	—	—

Valve that have not been actuated for a period of time may have a higher initial actuation torque.

Options

Mounting Options

Locking nut panel mounting

Orifice in. (mm)	Panel Hole in. (mm)	Panel Thickness in. (mm)
0.39 (10.0)	1.18 (30.0)	Max. 3/8 (9.5)
0.50 (12.7)	1.50 (38.0)	
0.75 (19.0)	1.50 (38.0)	

Screw hole panel mounting

Orifice in. (mm)	L1 in. (mm)	L2 in. (mm)	T1 in. (mm)	T2 in. (mm)
0.39 (10.0)	1.02 (26.0)	1.02 (26.0)	0.20 (5.0)	1.18 (30.0)
0.50 (12.7)	1.34 (34.0)	1.34 (34.0)	0.20 (5.0)	1.50 (38.0)
0.75 (19.0)	1.73 (44.0)	1.73 (44.0)	0.20 (5.0)	1.50 (38.0)

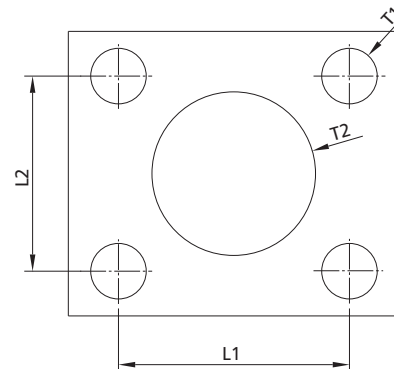

42 Series How to Order

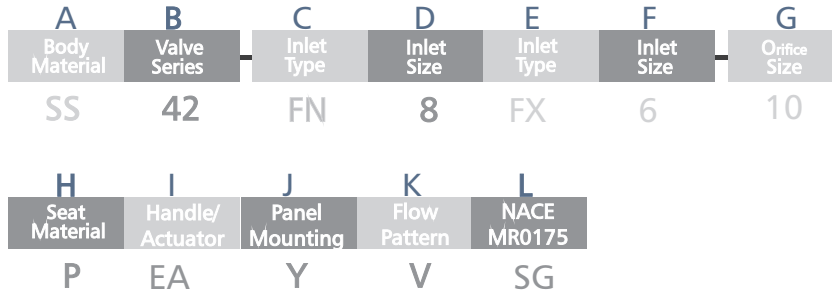

A	Body Material
SS:	316 SS
6L:	316L SS
S4:	304 SS
4L:	304L SS
S1:	321 SS
91:	F91
92:	F92
D5:	Duplex 2205
D7:	Duplex 2507
Ti:	Titanium
A20:	Alloy 20
M:	Alloy 400
INC:	Alloy 600
HC:	Alloy C-276

B	Valve Series
42:	42 Series Ball Valves

CE	Inlet/Outlet Type
FN	Female NPT
N	Male NPT
FR	Female BSPT
RT	Male BSPT
FM	Female ISO (for MRP)
MS	Male ISO (for MRG)
FP	Female BSPP (for RP)
BP	Male BSPP (for RG)
FX	Fractional Tube Fitting
MX	Metric Tube Fitting
UFB	Nut+Gasket+Fractional Bulge Nipple
UMB	Nut + Gasket + Metric Bulge Nipple

DF	Inlet/Outlet Size
2	1/8"
4	1/4"
6	3/8" or 6 mm
8	1/2" or 8 mm
10	10 mm
12	3/4" or 12 mm
14	14 mm or M14 x 1.5
16	1" or 16 mm
18	18 mm
20	1 1/4" or 20 mm or M20 x 1.5
22	22 mm or M22 x 1.5
25	25 mm
28	28 mm
30	30 mm
32	32 mm

G	Orifice Size
10:	0.39" (10.0 mm)
13:	0.5" (12.7 mm)
19:	0.71" (18.0 mm)
25:	0.98" (25.0 mm)

H	Seat Material
Standard with Virgin PVDF	
K	PCTFE
P	PEEK

I	Handle/Actuator
Standard with Balck Nylon Handle	
PA	Pneumatic Actuator
EA	Electric Actuator

J	Panel Mounting
Standard with no Panel Mounting	
Y	Yes

K	Flow Pattern
Standard is Straight Flow	
V	3-Way Vertical Pattern
H	3-Way Horizontal Pattern

L	NACE MR0175
Standard with no NACE applicable	
SG	With NACE MR0175

Remark:

- Standard thread pitch for metric threads are as follows:
M10 and below: 1 mm
M12 to M24: 1.5 mm
Standard thread pitch should be ignored in the ordering
NFmber, others should be specified.

Hex Bar Stock Ball Valves

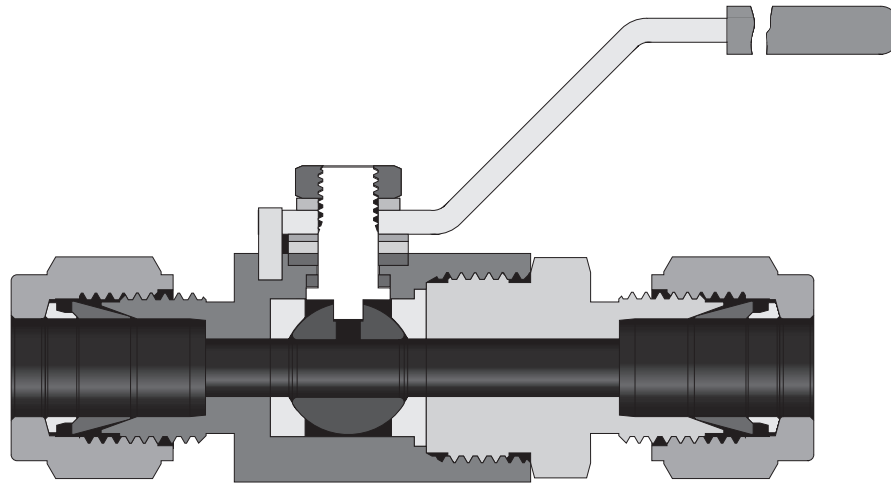

43 Series

- Compact barstock construction for high integrity.
- Blow-out proof design with internally loaded stem.
- Floating Ball design providing seat wear compensation.
- Micro-finished ball ensures a leak-tight shut-off on pressure.
- Standard lever handle, optional short handle.
- Standard maximum pressures:
 - PTFE seats: 68.9 bar (1000 psig)
 - TFM seats: 137 bar (2000 psig)
- Temperatures up to 450°F (232°C);
- Bi-directional flow.
- Low operating torque.
- Any reasonable connections available.
- Suitable for sour gas service; materials are selected in accordance with NACE MR0175/ISO 15156.
- Every valve is 100% factory tested with nitrogen.

Pressure vs. Temperature

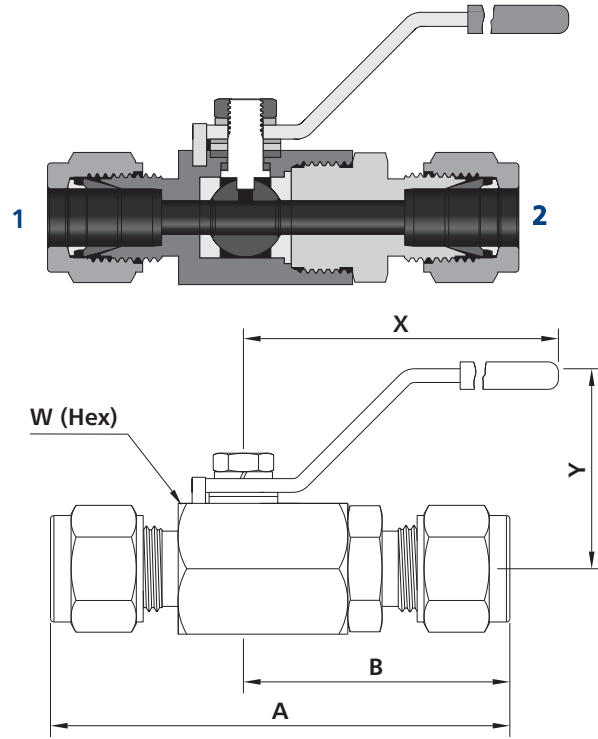
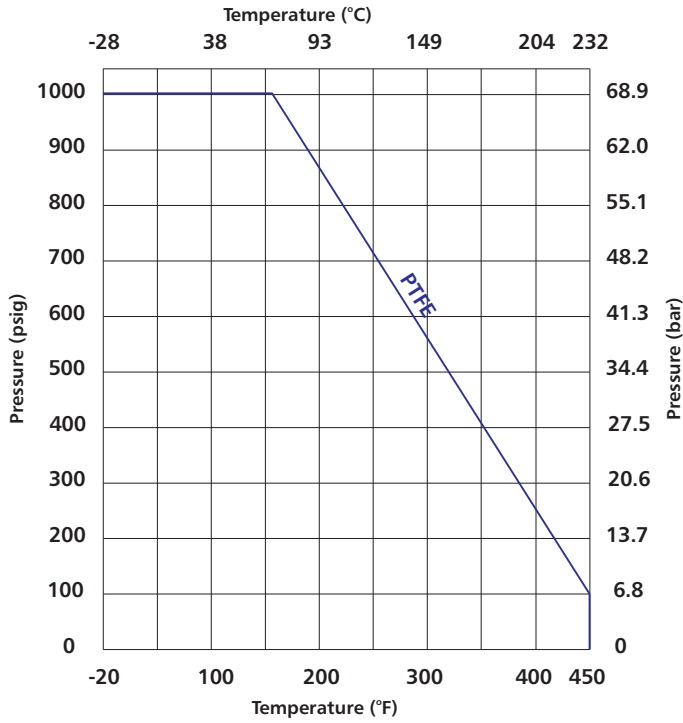

Standard Materials of Construction

Item	Component	Valve Body Material			
		316 SS	304 SS	316L SS	Brass
1	Body	316 SS/A276	304 SS/A276	316L SS/A276	Brass/B16
2	Front Seat	PTFE/D1710			
3	Ball	316 SS/A276			
4	Back Seat	PTFE/D1710			
5	End Connector	316 SS/A276	304 SS/A276	316L SS/A276	Brass/B16
6	Bottom Packing	PTFE/D1710			
7	Washer	316 SS/A276			
8	Handle	304 SS/A240 or aluminium			
9	Sleeve	Vinyl			
10	Stem Nut	316 SS/A194			
11	Gasket	304 SS			
12	Coned-disk Spring	304 SS/A240			
13	Pin	304 SS/A276			
14	Top Packing	PTFE/D1710			
15	Stem	316 SS/A276			

Other materials available upon request.

Dimensions

Basic Ordering Number	Connection Type and Size		Orifice in. (mm)	Cv	Dimension, in. (mm)				
	Connection 1	Connection 2			A	B	W	X	Y
<input type="checkbox"/> <input type="checkbox"/> 43-MX6-5	6 mm VFK	6 mm VFK	0.18 (4.8)	1.25	2.57 (62.5)	1.50 (38.1)	3/4 (19.05)	2.36 (60)	1.18 (30)
<input type="checkbox"/> <input type="checkbox"/> 43-MX8-5	8 mm VFK	8 mm VFK			2.63 (66.8)	1.53 (38.8)			
<input type="checkbox"/> <input type="checkbox"/> 43-FX4-5	1/4" VFK	1/4" VFK			2.57 (62.5)	1.50 (38.1)			
<input type="checkbox"/> <input type="checkbox"/> 43-FX5-5	5/16" VFK	5/16" VFK			2.63 (66.8)	1.53 (38.8)			
<input type="checkbox"/> <input type="checkbox"/> 43-FN2-5	1/8 Female NPT	1/8 Female NPT			1.85 (47.0)	1.08 (27.4)			
<input type="checkbox"/> <input type="checkbox"/> 43-FP2-5	1/8 Female BSPP	1/8 Female BSPP			1.97 (50.0)	1.14 (29.0)			
<input type="checkbox"/> <input type="checkbox"/> 43-FP4-5	1/4 Female BSPP	1/4 Female BSPP			1.85 (47.0)	1.08 (27.4)			
<input type="checkbox"/> <input type="checkbox"/> 43-FN4-5	1/4 Female NPT	1/4 Female NPT							
<input type="checkbox"/> <input type="checkbox"/> 43-MX10-7	10 mm VFK	10 mm VFK	0.28 (7.1)	2.50	2.87 (72.9)	1.68 (42.7)	7/8 (22.23)		
<input type="checkbox"/> <input type="checkbox"/> 43-FX6-7	3/8" VFK	3/8" VFK			2.03 (51.6)	1.18 (30.0)			
<input type="checkbox"/> <input type="checkbox"/> 43-FP6-7	3/8 Female BSPP	3/8 Female BSPP							
<input type="checkbox"/> <input type="checkbox"/> 43-FN6-7	3/8 Female NPT	3/8 Female NPT							
<input type="checkbox"/> <input type="checkbox"/> 43-MX12-10	12 mm VFK	12 mm VFK	0.35 (9.0)	9.25	3.15 (80.0)	1.83 (46.5)	15/16 (24.0)	3.15 (80)	1.54 (39)
<input type="checkbox"/> <input type="checkbox"/> 43-FX8-10	1/2" VFK	1/2" VFK			3.24 (82.2)	1.87 (47.5)			
<input type="checkbox"/> <input type="checkbox"/> 43-FX10-10	5/8" VFK	5/8" VFK			2.08 (53.0)	1.12 (28.5)			
<input type="checkbox"/> <input type="checkbox"/> 43-FP8-10	1/2 Female BSPP	1/2 Female BSPP							
<input type="checkbox"/> <input type="checkbox"/> 43-FN8-10	1/2 Female NPT	1/2 Female NPT							
<input type="checkbox"/> <input type="checkbox"/> 43-MX14-13	14 mm VFK	14 mm VFK	0.49 (12.5)	12.65	3.50 (88.9)	2.00 (50.8)	1 1/4 (31.75)	3.94 (100)	1.77 (45)
<input type="checkbox"/> <input type="checkbox"/> 43-MX16-13	16 mm VFK	16 mm VFK			2.48 (63.0)	1.30 (33.0)			
<input type="checkbox"/> <input type="checkbox"/> 43-MX18-13	18 mm VFK	18 mm VFK			2.39 (60.7)	1.20 (30.5)			
<input type="checkbox"/> <input type="checkbox"/> 43-FX12-13	3/4" VFK	3/4" VFK							
<input type="checkbox"/> <input type="checkbox"/> 43-FP12-13	3/4 Female BSPP	3/4 Female BSPP							
<input type="checkbox"/> <input type="checkbox"/> 43-FN12-13	3/4 Female NPT	3/4 Female NPT							
<input type="checkbox"/> <input type="checkbox"/> 43-MX22-16	22 mm VFK	22 mm VFK	0.63 (16.0)	17.35	3.96 (100.6)	2.24 (57.1)	1 5/8 (41.27)		
<input type="checkbox"/> <input type="checkbox"/> 43-MX25-16	25 mm VFK	25 mm VFK			4.31 (109.5)	2.42 (61.5)			
<input type="checkbox"/> <input type="checkbox"/> 43-FX16-16	1" VFK	1" VFK			3.25 (82.6)	1.63 (41.3)			
<input type="checkbox"/> <input type="checkbox"/> 43-FP16-16	1 Female BSPP	1 Female BSPP			3.00 (76.5)	1.50 (38.1)			
<input type="checkbox"/> <input type="checkbox"/> 43-FN16-16	1 Female NPT	1 Female NPT							

43 Series How to Order

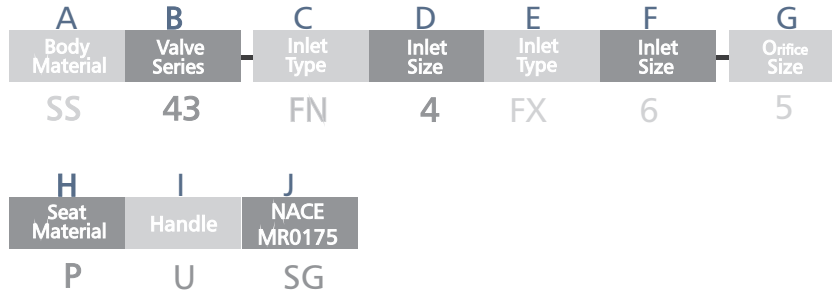

A	Body Material
SS:	316 SS
6L:	316L SS
S4:	304 SS
4L:	304L SS
S1:	321 SS
91:	F91
92:	F92
D5:	Duplex 2205
D7:	Duplex 2507
TI:	Titanium
A20:	Alloy 20
M:	Alloy 400
INC:	Alloy 600
HC:	Alloy C-276

B	Valve Series
43:	43 Series Ball Valves

CE	Inlet/Outlet Type
FN	Female NPT
N	Male NPT
FR	Female BSPT
RT	Male BSPT
FM	Female ISO (for MRP)
MS	Male ISO (for MRG)
FP	Female BSPP (for RP)
BP	Male BSPP (for RG)
FX	Fractional Tube Fitting
MX	Metric Tube Fitting
UFB	Nut+Gasket+ Fractional Bulge Nipple
UMB	Nut+ Gasket + Metric Bulge Nipple

DF	Inlet/Outlet Size
2	1/8"
4	1/4"
6	3/8" or 6 mm
8	1/2" or 8 mm
10	10 mm
12	3/4" or 12 mm
14	14 mm or M14 x 1.5
16	1" or 16 mm
18	18 mm
20	1 1/4" or 20 mm or M20 x 1.5
22	22 mm or M22 x 1.5
25	25 mm

G	Orifice Size
5:	0.18" (4.8 mm)
7:	0.28" (7.1 mm)
10:	0.35" (8.9 mm)
13:	0.47" (12.0 mm)
16:	0.63" (16.0 mm)

H	Seat Material
Standard with Virgin PVDF	
T	Reinforced PTFE

I	Handle
Standard with Lever Handle Control	
U	Black Short PP Handle

J	NACE MR0175
Standard with no NACE applicable	
SG	With NACE MR0175

Remark:

- Standard thread pitch for metric threads are as follows:
 M10 and below: 1 mm
 M12 to M24: 1.5 mm
 Standard thread pitch should be ignored in the ordering
 NFmber, others should be specified.

High Performance Ball Valves

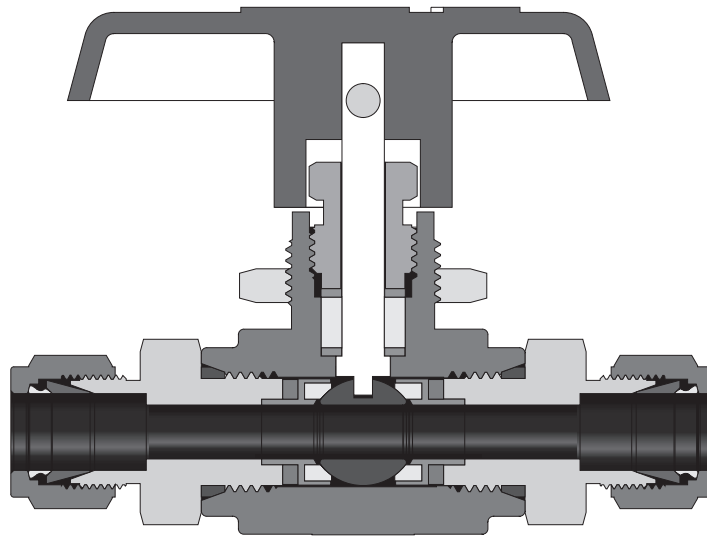

41 Series

- Maximum working pressure: 6000 psig (414 bar)
- Working temperature: -65°F to 450°F (-54°C to 232°C)
- Bi-directional flow for straight valves
- Low operating torque
- Handle as flow direction indicator
- Positive handle stop
- Manual, electric or pneumatic actuation available
- Options for handle color
- Leak-tight performance testing for every valve at the maximum working pressure with nitrogen

Pressure vs. Temperature

Stainless Steel Valves with PTFE Seat

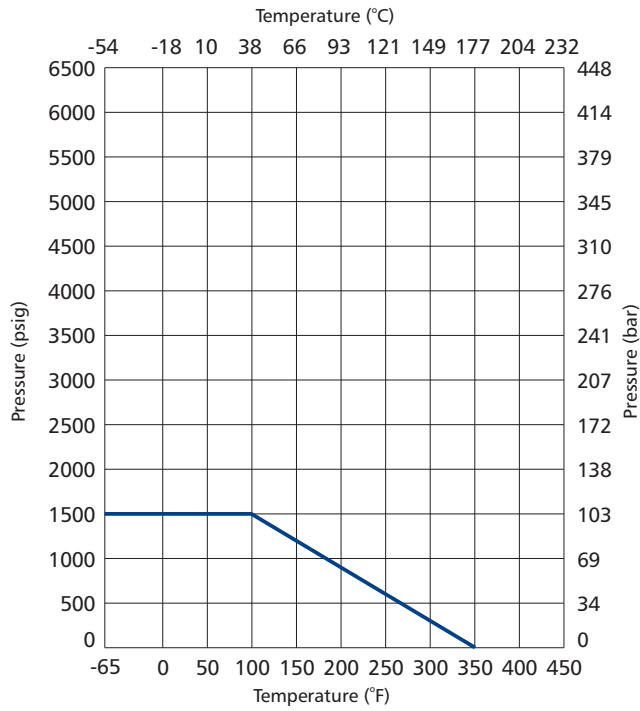

Stainless Steel Valves with PCTFE Seat

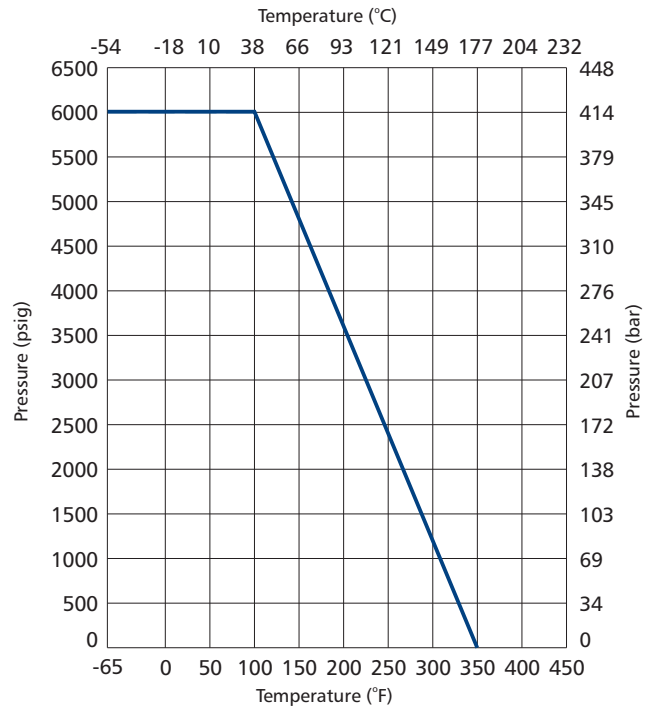

Stainless Steel Valves with PEEK Seat

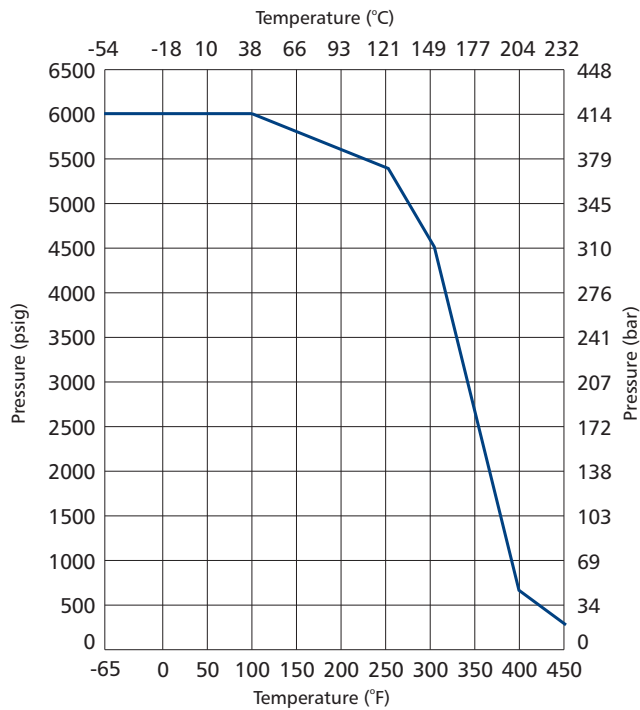

Pressure vs. Temperature

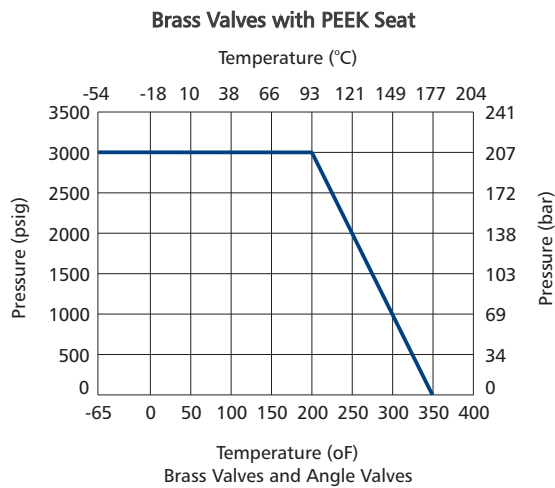
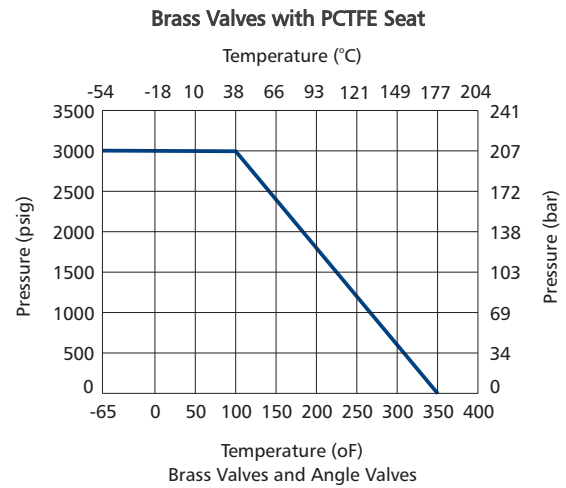
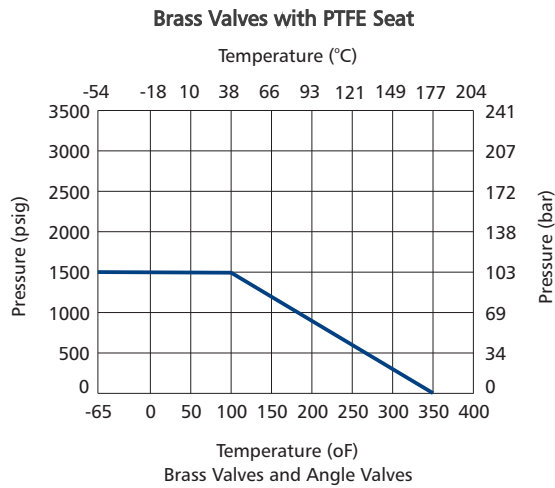

Temperature Ranges

Packing Materials	Temperature Range °F (°C)
PTFE	-40 to 450 (-40 to 232)
Buna-N	-40 to 250 (-40 to 121)
Fluorocarbon FKM	-10 to 400 (-23 to 204)
Neoprene	-40 to 250 (-40 to 121)

Standard Materials of Construction

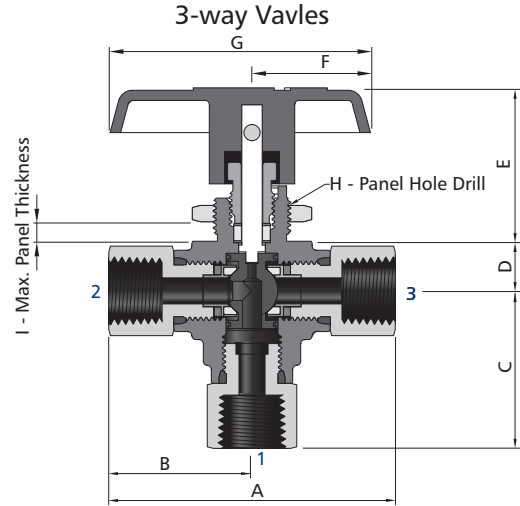
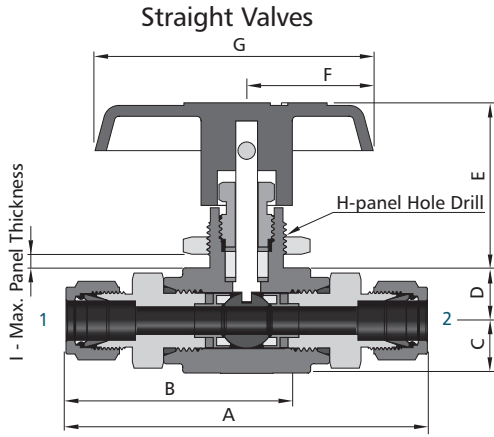

Straight Valves

Item		Valve Body Material	
		Stainless steel	Brass
1	Handle	Nylon or aluminium	
2	Packing Nut	316 SS/A276	C34000/B453
3	Panel Nut	316 SS/A276	C36000/B16
4	Body	CF8M/A351	C37700/B283
5	End connector	316 SS/A479	C36000/B16
6	Connector O-ring	PTFE	
7	Ball	316 SS/A479	
8	Seat	PTFE or PCTFE or PEEK	
9	Seat Retainer	316 SS/A276	C36000/B16
10	Stem Washer	316/A276	
11	Stem Packing	PTFE or fluorocarbon FKM or neoprene or buna N	
12	Stem	316 SS/A276	
13	Set Screw	Stainless steel	
Lubricants		Fluorinated-based and silicone-based	

3-way Vavles

Item	Component	Valve Body Material	
		Stainless Steel	Brass
1	Handle	Nylon or aluminium	
2	Packing Nut	316 SS/A276	C34000/B453
3	Panel Nut	316 SS/A276	C36000/B16
4	Body	CF8M /A351	C37700/B283
5	End Connector	316 SS/A479	C36000/B16
6	Connector O-ring	PTFE	
7	Packing	PTFE	
8	Seat	PTFE or PCTFE or PEEK	
9	Ball	316 SS/A479	
10	Seat Retainer	316 SS/A276	C36000/B16
11	Stem Back-up Ring	PEEK	
12	Stem Packing	PTFE or fluorocarbon FKM or neoprene or buna N	
13	Stem Washer	316 SS/A276	
14	Stem	316 SS/A276	
15	Set Screw	Stainless steel	
Lubricants		Fluorinated-based and silicone-based	

Straight Valves Dimensions

Basic Ordering Number	Connection Type and Size		Orifice in. (mm)	Cv	Dimension, in. (mm)												
	Connection 1	Connection 2			A	B	C	D	E	F	G	H	I				
<input type="checkbox"/> 41-FX1-1	1/16" VFK	1/16" VFK	0.052 (1.3)	0.06	2.60 (66.0)	1.30 (33.0)											
<input type="checkbox"/> 41-MX3-1	3 mm VFK	3 mm VFK			2.74 (69.6)	1.37 (34.8)											
<input type="checkbox"/> 41-FX2-2	1/8" VFK	1/8" VFK	0.093 (2.4)	0.21	2.72 (69.1)	1.36 (34.5)											
<input type="checkbox"/> 41-MX3-2	3 mm VFK	3 mm VFK			2.74 (69.6)	1.37 (34.8)											
<input type="checkbox"/> 41-FR2-4	1/8 Female BSPT	1/8 Female BSPT	0.165 (4.2)	0.93													
<input type="checkbox"/> 41-FP2-4	1/8 Female BSPP	1/8 Female BSPP			2.14 (54.4)	1.07 (27.2)	0.33 (8.4)	0.33 (8.4)	1.00 (25.4)	1.16 (29.5)	1.88 (47.8)	0.58 (14.7)	0.18 (4.6)				
<input type="checkbox"/> 41-FN2-4	1/8 Female NPT	1/8 Female NPT															
<input type="checkbox"/> 41-RT2-4	1/8 Male BSPT	1/8 Male BSPT															
<input type="checkbox"/> 41-BP2-4	1/8 Male BSPP	1/8 Male BSPP			2.36 (60.0)	1.18 (30.0)											
<input type="checkbox"/> 41-N2-4	1/8 Male NPT	1/8 Male NPT															
<input type="checkbox"/> 41-RT4-4	1/4 Male BSPT	1/4 Male BSPT															
<input type="checkbox"/> 41-BP4-4	1/4 Male BSPP	1/4 Male BSPP			2.70 (68.6)	1.35 (34.3)											
<input type="checkbox"/> 41-N4-4	1/4 Male NPT	1/4 Male NPT															
<input type="checkbox"/> 41-FX4-5	1/4" VFK	1/4" VFK			0.187 (4.7)	1.05	3.48 (88.4)	1.74 (44.2)									
<input type="checkbox"/> 41-MX6-5	6 mm VFK	6 mm VFK					3.50 (89.0)	1.75 (44.5)									
<input type="checkbox"/> 41-FX6-6	3/8" VFK	3/8" VFK			0.250 (6.4)	2.34	3.60 (91.4)	1.80 (45.7)									
<input type="checkbox"/> 41-MX8-6	8 mm VFK	8 mm VFK	0.250 (6.4)	2.34	3.56 (90.4)	1.78 (45.2)											
<input type="checkbox"/> 41-MX10-6	10 mm VFK	10 mm VFK			3.62 (92.0)	1.81 (46.0)											
<input type="checkbox"/> 41-FR4-6	1/4 Female BSPT	1/4 Female BSPT															
<input type="checkbox"/> 41-FP4-6	1/4 Female BSPP	1/4 Female BSPP			3.02 (76.8)	1.51 (38.4)	0.42 (10.7)	0.47 (11.9)	1.48 (37.5)	0.75 (19.05)	2.52 (64.0)	0.77 (19.6)	0.25 (6.4)				
<input type="checkbox"/> 41-FN4-6	1/4 Female NPT	1/4 Female NPT															
<input type="checkbox"/> 41-RT4-6	1/4 Male BSPT	1/4 Male BSPT															
<input type="checkbox"/> 41-BP4-6	1/4 Male BSPP	1/4 Male BSPP															
<input type="checkbox"/> 41-N4-6	1/4 Male NPT	1/4 Male NPT															
<input type="checkbox"/> 41-RT6-6	3/8 Male BSPT	3/8 Male BSPT															
<input type="checkbox"/> 41-BP6-6	3/8 Male BSPP	3/8 Male BSPP															
<input type="checkbox"/> 41-N6-6	3/8 Male NPT	3/8 Male NPT															
<input type="checkbox"/> 41-FX8-10	1/2" VFK	1/2" VFK			0.406 (10.3)	6.42	4.68 (118.8)	2.34 (59.4)									
<input type="checkbox"/> 41-FX12-10	3/4" VFK	3/4" VFK							0.69 (17.5)	0.70 (17.8)							
<input type="checkbox"/> 41-MX12-10	12 mm VFK	12 mm VFK															
<input type="checkbox"/> 41-MX14-10	14 mm VFK	14 mm VFK					4.66 (118.4)	2.33 (59.2)									
<input type="checkbox"/> 41-MX16-10	16 mm VFK	16 mm VFK															
<input type="checkbox"/> 41-MX18-10	18 mm VFK	18 mm VFK															
<input type="checkbox"/> 41-MX20-10	20 mm VFK	20 mm VFK															
<input type="checkbox"/> 41-MX22-10	22 mm VFK	22 mm VFK					4.84 (123.0)	2.42 (61.5)	0.89 (22.5)	0.89 (22.5)							
<input type="checkbox"/> 41-FR6-10	3/8 Female BSPT	3/8 Female BSPT															
<input type="checkbox"/> 41-FP6-10	3/8 Female BSPP	3/8 Female BSPP					3.90 (99.0)	1.95 (49.5)									
<input type="checkbox"/> 41-FN6-10	3/8 Female NPT	3/8 Female NPT															
<input type="checkbox"/> 41-FR8-10	1/2 Female BSPT	1/2 Female BSPT									1.71 (43.5)	1.42 (36.0)	4.0 (101.6)	0.90 (22.9)	0.38 (9.7)		
<input type="checkbox"/> 41-FP8-10	1/2 Female BSPP	1/2 Female BSPP					4.30 (109.2)	2.15 (54.6)									
<input type="checkbox"/> 41-FN8-10	1/2 Female NPT	1/2 Female NPT															
<input type="checkbox"/> 41-FR12-10	3/4 Female BSPT	3/4 Female BSPT															
<input type="checkbox"/> 41-FP12-10	3/4 Female BSPP	3/4 Female BSPP					4.36 (110.8)	2.18 (55.4)	0.69 (17.5)	0.70 (17.8)							
<input type="checkbox"/> 41-FN12-10	3/4 Female NPT	3/4 Female NPT					4.50 (114.2)	2.25 (57.1)									
<input type="checkbox"/> 41-RT8-10	1/2 Male BSPT	1/2 Male BSPT															
<input type="checkbox"/> 41-BP8-10	1/2 Male BSPP	1/2 Male BSPP															
<input type="checkbox"/> 41-N8-10	1/2 Male NPT	1/2 Male NPT															
<input type="checkbox"/> 41-RT12-10	3/4 Male BSPT	3/4 Male BSPT					4.44 (112.8)	2.22 (56.4)									
<input type="checkbox"/> 41-BP12-10	3/4 Male BSPP	3/4 Male BSPP															
<input type="checkbox"/> 41-N12-10	3/4 Male NPT	3/4 Male NPT															

3-way Valves Dimensions

Basic Ordering Number	Connection type and size		Orifice in. (mm)	Cv	Dimension, in. (mm)																
	Connection 1	Connection 2/3			A	B	C	D	E	F	G	H	I								
<input type="checkbox"/> 41-FX1-V1	1/16" VFK	1/16" VFK	0.052 (1.3)	0.06	2.60 (66.0)	1.30 (33.0)	1.39 (35.3)														
<input type="checkbox"/> 41-MX3-V1	3 mm VFK	3 mm VFK			2.74 (69.6)	1.37 (34.8)															
<input type="checkbox"/> 41-FX2-V2	1/8" VFK	1/8" VFK	0.093 (2.4)	0.21	2.72 (69.1)	1.36 (34.5)															
<input type="checkbox"/> 41-MX3-V2	3 mm VFK	3 mm VFK	2.74 (69.6)		1.37 (34.8)																
<input type="checkbox"/> 41-FR2-V4	1/8 Female BSPT	1/8 Female BSPT	0.165 (4.2)	0.63	2.14 (54.4)	1.07 (27.2)	1.15 (29.2)	0.33 (8.4)	1.00 (25.4)	1.16 (29.5)	1.88 (47.8)	0.58 (14.7)	0.18 (4.6)								
<input type="checkbox"/> 41-FP2-V4	1/8 Female BSPP	1/8 Female BSPP																			
<input type="checkbox"/> 41-FN2-V4	1/8 Female NPT	1/8 Female NPT																			
<input type="checkbox"/> 41-RT2-V4	1/8 Male BSPT	1/8 Male BSPT			2.36 (60.0)	1.18 (30.0)	1.26 (32.0)														
<input type="checkbox"/> 41-BP2-V4	1/8 Male BSPP	1/8 Male BSPP																			
<input type="checkbox"/> 41-N2-V4	1/8 Male NPT	1/8 Male NPT																			
<input type="checkbox"/> 41-RT4-V4	1/ 4 Male BSPT	1/4 Male BSPT			2.70 (68.6)	1.35 (34.3)	1.43 (36.3)														
<input type="checkbox"/> 41-BP4-V4	1/ 4 Male BSPP	1/4 Male BSPP																			
<input type="checkbox"/> 41-N4-V4	1/ 4 Male NPT	1/4 Male NPT																			
<input type="checkbox"/> 41-FX4-V5	1/ 4" VFK	1/4" VFK												0.187(4.7)	0.75	3.48 (88.4)	1.74 (44.2)	1.89 (48.0)			
<input type="checkbox"/> 41-MX6-V5	6 mm VFK	6 mm VFK	3.50 (89.0)	1.75 (44.5)	1.88 (47.8)																
<input type="checkbox"/> 41-FX6-V6	3/8" VFK	3/8" VFK	0.250(6.4)	1.35	3.60 (91.4)	1.80 (45.7)	1.94 (49.3)	0.47 (11.9)	1.48 (37.5)	0.75 (19.1)	2.52 (64.0)	0.77 (19.6)	0.25 (6.4)								
<input type="checkbox"/> 41-MX8-V6	8 mm VFK	8 mm VFK	3.56 (90.4)		1.78 (45.2)	1.91 (48.5)															
<input type="checkbox"/> 41-MX10-V6	10 mm VFK	10 mm VFK	0.250(6.4)	1.35	3.62 (92.0)	1.81 (46.0)	1.95 (49.5)														
<input type="checkbox"/> 41-FR4-V6	1/4 Female BSPT	1/4 Female BSPT			3.02 (76.8)	1.51 (38.4)	1.65 (41.9)														
<input type="checkbox"/> 41-FP4-V6	1/4 Female BSPP	1/4 Female BSPP																			
<input type="checkbox"/> 41-FN4-V6	1/4 Female NPT	1/4 Female NPT																			
<input type="checkbox"/> 41-RT4-V6	1/4 Male BSPT	1/4 Male BSPT			3.24 (82.2)	1.62 (41.1)	1.76 (44.7)														
<input type="checkbox"/> 41-BP4-V6	1/4 Male BSPP	1/4 Male BSPP																			
<input type="checkbox"/> 41-N4-V6	1/4 Male NPT	1/4 Male NPT																			
<input type="checkbox"/> 41-RT6-V6	3/8 Male BSPT	3/8 Male BSPT																			
<input type="checkbox"/> 41-BP6-V6	3/8 Male BSPP	3/8 Male BSPP																			
<input type="checkbox"/> 41-N6-V6	3/8 Male NPT	3/8 Male NPT																			
<input type="checkbox"/> 41-FX8-V10	1/2" VFK	1/2" VFK	0.406 (10.3)	3.62	4.68 (118.8)	2.34(59.4)	2.68(68.0)	0.70 (17.8)	1.71 (43.5)	1.42 (36.0)	4.00 (101.6)	0.90 (22.9)	0.38 (9.7)								
<input type="checkbox"/> 41-FX12-V10	3/4" VFK	3/4" VFK			4.66(118.4)	2.33 (59.2)	2.67 (67.8)														
<input type="checkbox"/> 41-MX12-V10	12 mm VFK	12 mm VFK																			
<input type="checkbox"/> 41-MX14-V10	14 mm VFK	14 mm VFK																			
<input type="checkbox"/> 41-MX16-V10	16 mm VFK	16 mm VFK			4.84 (123.0)	2.42 (61.5)	2.76 (70.1)														
<input type="checkbox"/> 41-MX18-V10	18 mm VFK	18 mm VFK																			
<input type="checkbox"/> 41-MX20-V10	20 mm VFK	20 mm VFK																			
<input type="checkbox"/> 41-MX22-V10	22 mm VFK	22 mm VFK			3.90 (99.0)	1.95 (49.5)	2.29 (58.2)														
<input type="checkbox"/> 41-FN6-V10	3/8 Female NPT	3/8 Female NPT			4.30 (109.2)	2.15 (54.6)	2.49 (63.2)														
<input type="checkbox"/> 41-FN8-V10	1/2 Female NPT	1/2 Female NPT																			
<input type="checkbox"/> 41-FP12-V10	3/4 Female BSPP	3/4 Female BSPP			4.44 (112.8)	2.22 (56.4)	2.59 (65.8)														
<input type="checkbox"/> 41-FN12-V10	3/4 Female NPT	3/4 Female NPT																			
<input type="checkbox"/> 41-RT8-V10	1/2 Male BSPT	1/2 Male BSPT																			
<input type="checkbox"/> 41-BP8-V10	1/2 Male BSPP	1/2 Male BSPP																			
<input type="checkbox"/> 41-N8-V10	1/2 Male NPT	1/2 Male NPT																			
<input type="checkbox"/> 41-RT12-V10	3/4 Male BSPT	3/4 Male BSPT																			
<input type="checkbox"/> 41-BP12-V10	3/4 Male BSPP	3/4 Male BSPP																			
<input type="checkbox"/> 41-N12-V10	3/4 Male NPT	3/4 Male NPT																			

41 Series How to Order

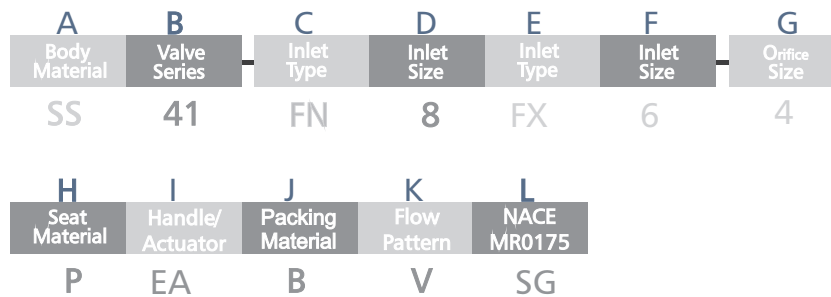

A	Body Material
SS:	316 SS
6L:	316L SS
S4:	304 SS
4L:	304L SS
S1:	321 SS
91:	F91
92:	F92
D5:	Duplex 2205
D7:	Duplex 2507
TI:	Titanium
A20:	Alloy 20
M:	Alloy 400
INC:	Alloy 600
HC:	Alloy C-276

B	Valve Series
41:	41 Series Ball Valves

CE	Inlet/Outlet Type
FN	Female NPT
N	Male NPT
FR	Female BSPT
RT	Male BSPT
FM	Female ISO (for MRP)
MS	Male ISO (for MRG)
FP	Female BSPP (for RP)
BP	Male BSPP (for RG)
FX	Fractional Tube Fitting
MX	Metric Tube Fitting
UFB	Nut+Gasket+ Fractional Bulge Nipple
UMB	Nut+ Gasket + Metric Bulge Nipple

DF	Inlet/Outlet Size
2	1/8"
4	1/4"
6	3/8" or 6 mm
8	1/2" or 8 mm
10	10 mm
12	3/4" or 12 mm
14	14 mm or M14 x 1.5
16	1" or 16 mm
18	18 mm
20	1 1/4" or 20 mm or M20 x 1.5
22	22 mm or M22 x 1.5
24	M24 x1.5 mm

G	Orifice Size
1:	0.052" (1.3 mm)
2:	0.093" (2.4 mm)
3:	0.125" (3.2 mm)
4:	0.165" (4.2 mm)
5:	0.187" (4.7 mm)
6:	0.25" (6.4 mm)
10:	0.406" (10.3 mm)

H	Seat Material
Standard with Virgin PTFE	
K	PCTFE
P	PEEK

I	Packing Material
Standard with Reinforced PTFE	
B	Buna N
N	Neoprene
V	Fluorocarbon FKM

J	Handle/Actuator
Standard with Balck Nylon Handle	
PA	Pneumatic Actuator
EA	Electric Actuator

K	Flow Pattern
Standard is Straight Flow	
V	3-Way Vertical Pattern

L	NACE MR0175
Standard with no NACE applicable	
SG	With NACE MR0175

Remark:

- Standard thread pitch for metric threads are as follows:
M10 and below: 1 mm
M12 to M24: 1.5 mm
Standard thread pitch should be ignored in the ordering NFmber, others should be specified.

One-piece Instrument Ball Valves

46 Series

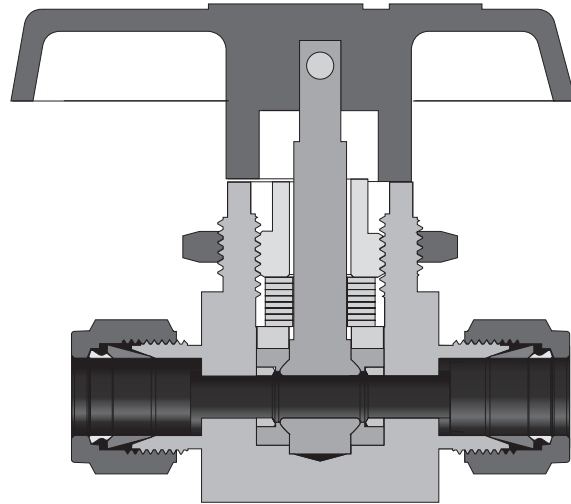

46 Series

- Maximum working pressure: 3000 psig (207 bar)
- Working temperature: -65°F to 300°F (-54°C to 148°C)
- Size from 1/16" to 3/4" or 3 mm to 18 mm
- 2-, 3-, 4-, 5-, 6- and 7-way models for on-off, switching and crossover service available
- One-piece body and one piece ball stem
- In-line inspection and repair after system relieved by top entry design
- Thermal cycle performance improved and wear compensated by live-loaded design
- Any reasonable connections available
- Pneumatic and electric actuation available
- Handle of different colors available for option
- Full operating pressure at any port
- Leak-tight performance testing for every valve at the maximum working pressure with nitrogen

Pressure vs. Temperature

2-, 3-way Valves

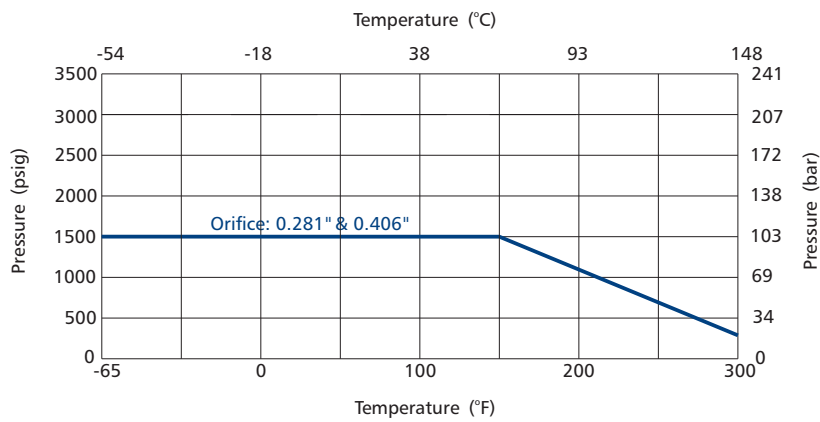
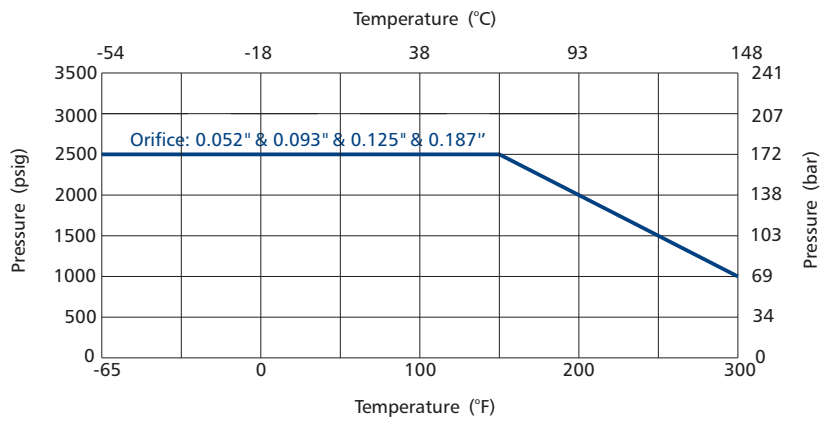
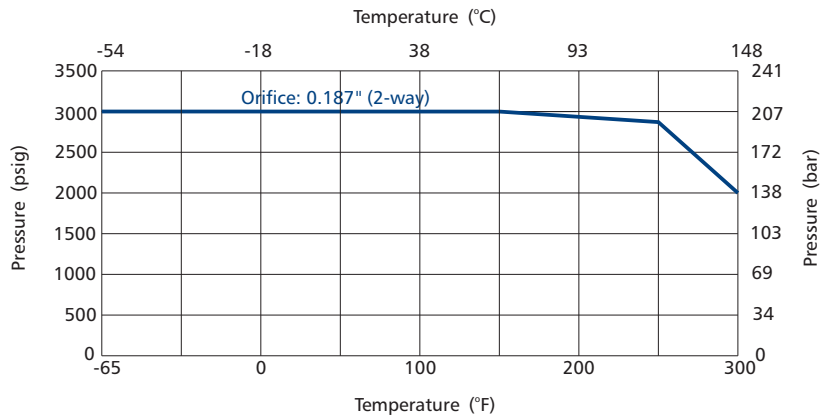

4-,5-,6-,7-way Valves

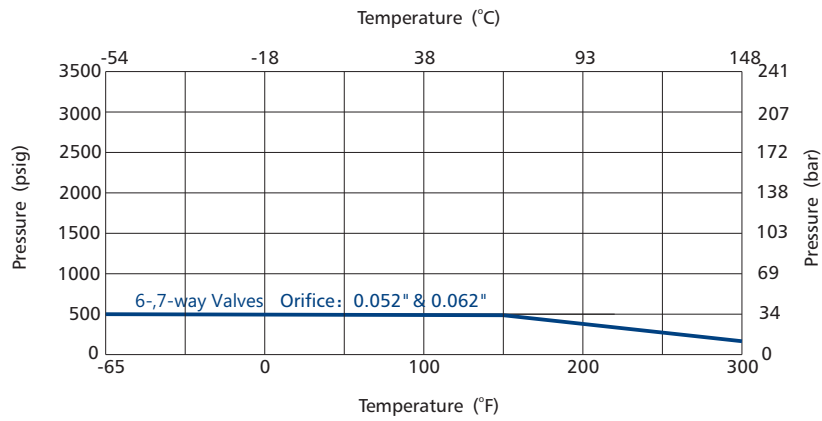
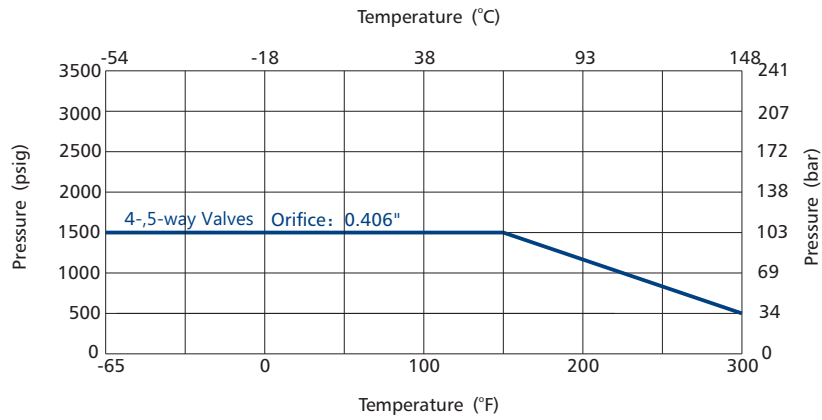
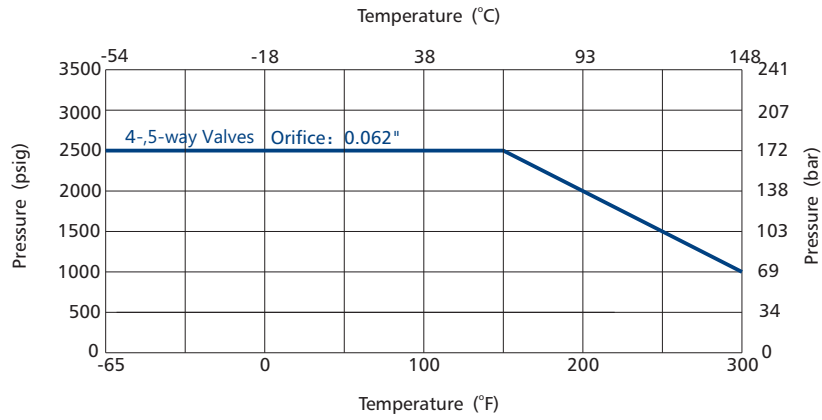

Crossover (4-,6-way) Valves

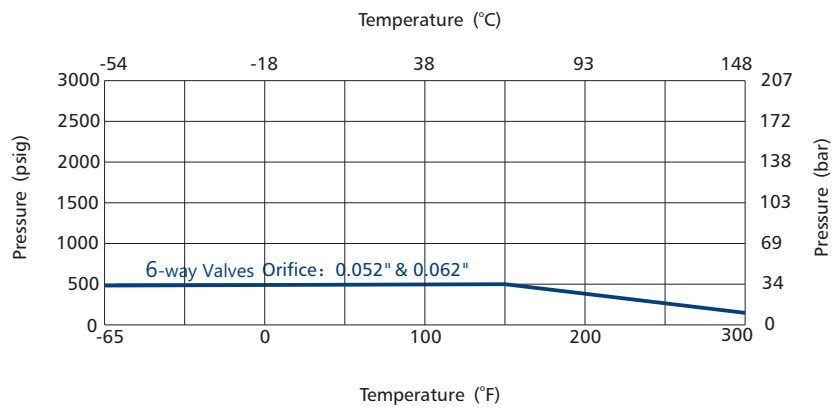
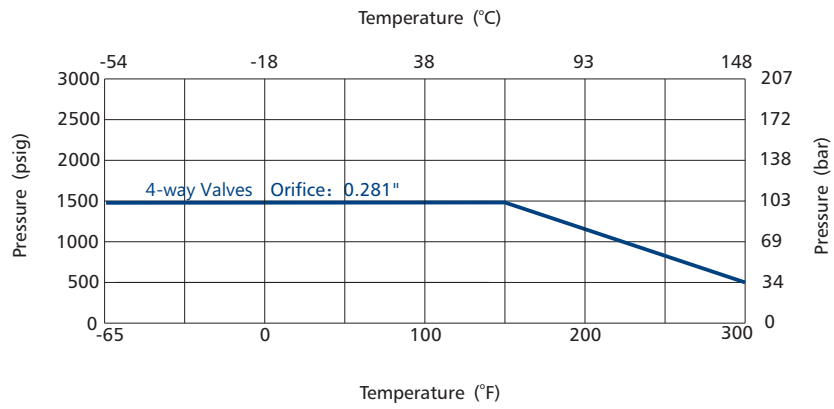
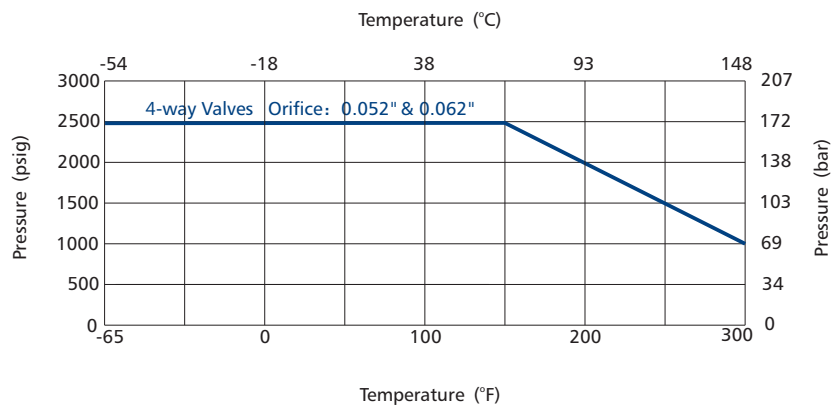

Standard Materials of Construction

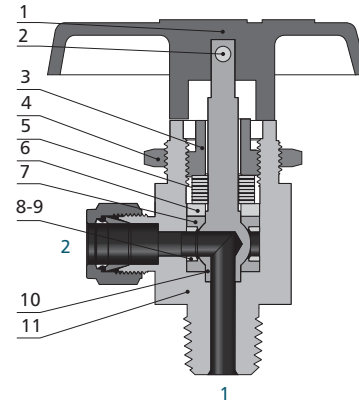
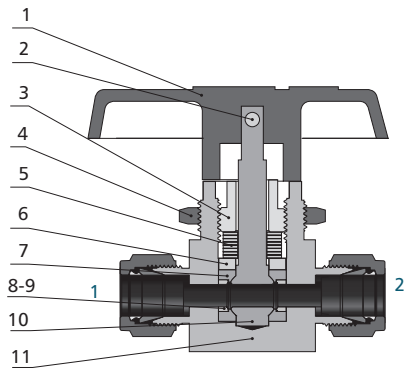

Item	Component	Valve Body Material		
		Stainless Steel	Brass	Alloy 400
		Material Grade/ASTM Specification		
1	Handle	Nylon or Aluminium		
2	Set Screw	S17400 SS/A564		
3	Packing Bolt	Powdered metal 300 series SS /B783 or 316 SS/A276,A479	Brass C36000/B16	Alloy 400/B164
4	Panel Nut	Powdered metal 300 series SS /B783 or 316 SS/A276,A479	Brass C36000/B16	Powdered metal 300 series SS /B783 or 316 SS/A276,A479
5	Dishing Spring	S17700/A693		
6	Gland	Powdered metal 300 series SS /B783 or 316 SS/A276	Brass C36000/B16	Alloy 400/B164
7	Packing Seat	PTFE/D1710 or UHMWPE/D4020		
8	Support Ring	Fluorocarbon-coated metal 300 series SS/B783	Fluorocarbon-coated brass powdered metal	Fluorocarbon-coated alloy 400 powdered metal
9	Support Disc			
10	Ball Stem	316 SS/A276	Brass C36000/B16	Alloy 400/B164
11	Body	316 SS/A276	Brass C36000/B16	Alloy 400/B164
Wetted Lubricant		Fluorinated-based and silicone-based		
Non-wetted Lubricant		Molybdenum disulfide with hydrocarbon binder coat		

Dimensions

2-way Vavles

Straight

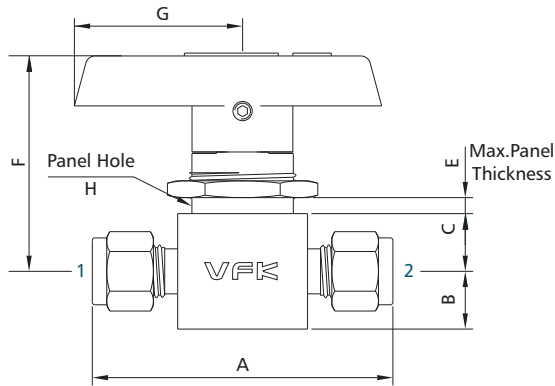

Open Close

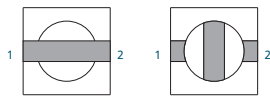

Angle

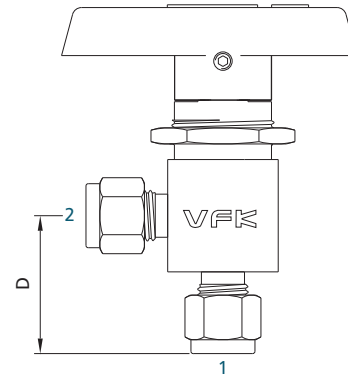

Open Close

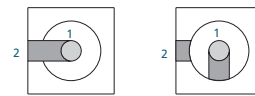

Basic Ordering Number	Connection Type and Size	Orifice in. (mm)	Cv		Dimension, in.(mm)								
			Straight	Angle	A	B	C	D	E	F	G	H	
□□460-FX1	1/16" VFK	0.052 (1.3)	0.10	—	1.68 (42.7)								
□□462-FX2	1/8" VFK	0.093 (2.4)	0.20	0.15	2.01 (51.1)	0.28 (7.1)	0.34 (8.6)	0.97 (24.6)	1/4 (6.4)	1.36 (34.5)	1.12 (28.4)	19/32 (15.1)	
□□463-FX4	1/4" VFK	0.125 (3.2)	0.60	0.35	2.21 (56.1)			1.07 (27.2)					
□□465-FX4		0.187 (4.8)	1.40	0.90	2.39 (60.7)	0.38 (9.7)	0.44 (11.2)	1.17 (29.7)	3/16 (4.8)	1.47 (37.3)	1.53 (38.9)	25/32 (19.8)	
□□465-FX6	3/8" VFK		1.50		2.58 (65.5)			1.29 (32.8)					
□□467-FX6		0.281 (7.1)	6.00	2.00	3.05 (77.5)	0.56 (14.2)	0.56 (14.2)	1.43 (36.3)		2.07 (52.6)	2.00 (50.8)	1 1/8 (28.6)	
□□4610-FX8	1/2" VFK	0.406 (10.3)	12.00	4.60	3.92 (99.6)	0.69 (17.5)	0.69 (17.5)	1.74 (44.2)	3/8 (9.5)				
□□4610-FX12	3/4" VFK		6.40	3.80						2.43 (61.7)	3.00 (76.2)	1 1/2 (38.1)	
□□462-MX3	3 mm VFK	0.093 (2.4)	0.20	0.15	2.01 (51.1)	0.28 (7.1)	0.34 (8.6)	0.97 (24.6)	1/4 (6.4)	1.36 (34.5)	1.36 (34.5)	19/32 (15.1)	
□□463-MX6	6 mm VFK	0.125 (3.2)	0.60	0.35	2.21 (56.1)			1.07 (27.2)					
□□465-MX6		0.187 (4.8)	1.40	0.90	2.39 (60.7)	0.38 (9.7)	0.44 (11.2)	1.17 (29.7)	3/16 (4.8)	1.47 (37.3)	1.47 (37.3)	25/32 (19.8)	
□□465-MX8	8 mm VFK		1.50		2.46 (62.5)			1.20 (30.5)					
□□467-MX10	10 mm VFK	0.281 (7.1)	6.00	2.00	3.07 (78.0)	0.56 (14.2)	0.56 (14.2)	1.43 (36.3)	3/8 (9.5)	2.07 (52.6)	2.07 (52.6)	1 1/8 (28.6)	
□□4610-MX12	12 mm VFK	0.406 (10.3)	12.00	4.60	3.92 (99.6)	0.69 (17.5)	0.69 (17.5)	1.74 (44.2)			2.43 (61.7)	2.43 (61.7)	1 1/2 (38.1)

Basic Ordering Number	Connection Type and Size	Orifice in. (mm)	Cv		Dimension, in.(mm)							
			Straight	Angle	A	B	C	D	E	F	G	H
□□463-FN2	1/8 Female NPT	0.125 (3.2)	0.50	0.30	1.63 (41.4)	0.28 (7.1)	0.34 (8.6)	0.81 (20.6)	1/4 (6.4)	1.36 (34.5)	1.12 (28.4)	19/32 (15.1)
□□465-FN2		0.187 (4.8)	1.20	0.70	2.0 (50.8)	0.38 (9.7)	0.44 (11.2)	1.0 (25.4)	3/16 (4.8)	1.47 (37.3)	1.53 (38.9)	25/32 (19.8)
□□465-FN4	1/4 Female NPT	0.90	0.75	2.06 (52.3)	1.03 (26.2)							
□□467-FN4		3/8 Female NPT	0.281 (7.1)	3.00	1.70	2.50 (63.5)	0.56 (14.2)	0.56 (14.2)	1.25 (31.8)	3/8 (9.5)	2.07 (52.6)	2.00 (50.8)
□□467-FN6	2.60			1.50								
□□4610-FN8	1/2 Female NPT	0.406 (10.3)	6.30	3.50	3.12 (79.2)	0.69 (17.5)	0.69 (17.5)	1.56 (39.6)		2.43 (61.7)	3.00 (76.2)	1 1/2 (38.1)
□□465-N4	1/4 Female NPT	0.187 (4.8)	1.20	0.75	2.00 (50.8)	0.38 (9.7)	0.44 (11.2)	1.03 (26.2)	3/16 (4.8)	1.47 (37.3)	1.53 (38.9)	25/32 (19.8)
□□465-FR4	1/4 Female BSPT		0.90		2.06 (52.3)							
□□467-FR6	3/8 Female BSPT	0.281 (7.1)	2.60	—	2.50 (63.5)	0.56 (14.2)	0.56 (14.2)	—	3/8 (9.5)	2.07 (52.6)	2.00 (50.8)	1 1/8 (28.6)
□□4610-FR8	1/2 Female BSPT	0.406 (10.3)			6.30	3.12 (79.2)	0.69 (17.5)					
□□465-N4FX4	1/4 Male NPT 1/4" VFK	0.187 (4.8)	1.60	0.75	2.20 (55.9)	0.38 (9.7)	0.44 (11.2)	1.03 (26.2)	3/16 (4.8)	1.47 (37.3)	1.53 (38.9)	25/32 (19.8)

Switching (3-,4-,5-,6- and 7-way) Valves

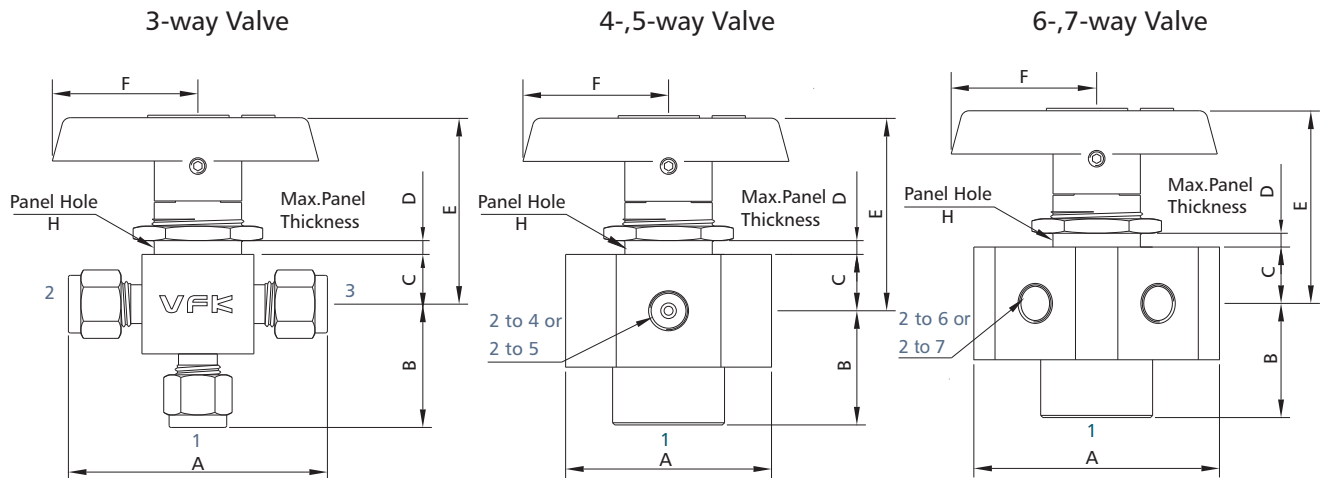

3L Flow Pattern



4L Flow Pattern



5L Flow Pattern



6L Flow Pattern



7L Flow Pattern



Special Flow Pattern

3HL Flow Pattern



5H Flow Pattern



5LL Flow Pattern



5HL Flow Pattern



Basic Ordering Number	Connection Type and Size	Orifice in. (mm)	Cv	Dimension, in.(mm)							
				A	B	C	D	E	F	H	
3-way Valve											
□□461-FX1-3L	1/16" VFK	0.052 (1.3)	0.08	1.68 (42.7)	0.81 (20.6)						
□□462-FX2-3L	1/8" VFK	0.093 (2.4)	0.15	2.01 (51.1)	0.97 (24.6)	0.34 (8.6)	1/4 (6.4)	1.36 (34.5)	1.13 (28.7)	19/32 (15.1)	
□□463-FX4-3L	1/4" VFK	0.125 (3.2)	0.35	2.21 (56.1)	1.07 (27.2)						
□□465-FX4-3L		0.187 (4.8)	0.90	2.39 (60.7)	1.17 (29.7)	0.44 (11.2)	3/16 (4.8)	1.47 (37.3)	1.53 (38.9)	25/32 (19.8)	
□□467-FX6-3L	3/8" VFK	0.281 (7.1)	2.00	2.89 (73.4)	1.43 (36.3)	0.56 (14.2)		2.07 (52.6)	2.00 (50.8)	1 1/8 (28.6)	
□□4610-FX8-1-3L	1/2" VFK	0.406 (10.3)	4.60	3.48 (88.4)	1.74 (44.2)	0.69 (17.5)	3/8 (9.5)	2.43 (61.7)	3.00 (76.2)	1 1/2 (38.1)	
□□4610-FX12-3L	3/4" VFK		4.90								

Basic Ordering Number	Connection Type and Size	Orifice in. (mm)	Cv	Dimension, in.(mm)						
				A	B	C	D	E	F	H
<input type="checkbox"/> 462-MX3-3L	3 mm VFK	0.093 (2.4)	0.15	2.01 (51.1)	0.97 (24.6)	0.34 (8.6)	1/4 (6.4)	1.36 (34.5)	1.13 (28.7)	19/32 (15.1)
<input type="checkbox"/> 463-MX6-3L	6 mm VFK	0.125 (3.2)	0.35	2.21 (56.1)	1.07 (27.2)					
<input type="checkbox"/> 465-MX6-3L		0.187 (4.8)	0.90	2.39 (60.7)	1.17 (29.7)	0.44 (11.2)	3/16 (4.8)	1.47 (37.3)	1.53 (38.9)	25/32 (19.8)
<input type="checkbox"/> 465-MX8-3L		8 mm VFK	0.281 (7.1)	0.80	2.46 (62.5)					
<input type="checkbox"/> 467-MX10-3L	10 mm VFK	0.281 (7.1)	2.00	2.89 (73.4)	1.43 (36.3)	0.56 (14.2)	3/8 (9.5)	2.07 (52.6)	2.00 (50.8)	1 1/8 (28.6)
<input type="checkbox"/> 467-MX12-3L	12 mm VFK	0.406 (10.3)	4.60	3.48 (88.4)	1.74 (44.2)	0.69 (17.5)		2.43 (61.7)	3.00 (76.2)	1 1/2 (38.1)
<input type="checkbox"/> 463-FN2-3L	1/8 Female NPT	0.125 (3.2)	0.30	1.63 (41.4)	0.81 (20.6)	0.34 (8.6)	1/4 (6.4)	1.36 (34.5)	1.13 (28.7)	19/32 (15.1)
<input type="checkbox"/> 465-FN4-3L	1/4 Female NPT	0.187 (4.8)	0.75	2.06 (52.3)	1.03 (26.2)	0.44 (11.2)	3/16 (4.8)	1.47 (37.3)	1.53 (38.9)	25/32 (19.8)
<input type="checkbox"/> 467-FN4-3L		0.281 (7.1)	1.70	2.50 (63.5)	1.25 (31.8)	0.56 (14.2)	3/8 (9.5)	2.07 (52.6)	2.00 (50.8)	1 1/8 (28.6)
<input type="checkbox"/> 467-FN6-3L		3/8 Female NPT	1.50	3.13 (79.5)	1.56 (39.6)	0.69 (17.5)				
<input type="checkbox"/> 4610-FN8-3L	1/2 Female NPT	0.406 (10.3)	3.50	3.13 (79.5)	1.56 (39.6)	0.69 (17.5)	3/8 (9.5)	2.43 (61.7)	3.00 (76.2)	1 1/2 (38.1)
<input type="checkbox"/> 465-FR4-3L	1/4 Female BSPT	0.187 (4.8)	0.75	2.06 (52.3)	1.03 (26.2)	0.44 (11.2)	3/16 (4.8)	1.47 (37.3)	1.53 (38.9)	25/32 (19.8)
<input type="checkbox"/> 467-FR6-3L	3/8 Female BSPT	0.281 (7.1)	1.50	2.50 (63.5)	1.25 (31.8)	0.56 (14.2)	3/8 (9.5)	2.07 (52.6)	2.00 (50.8)	1 1/8 (28.6)
<input type="checkbox"/> 4610-FR8-3L	1/2 Female BSPT	0.406 (10.3)	3.50	3.13 (79.5)	1.56 (39.6)	0.69 (17.5)		2.43 (61.7)	3.00 (76.2)	1 1/2 (38.1)

4- & 5-way Valve

<input type="checkbox"/> 461-FX2-4	1/8" VFK	0.062 (1.6)	0.07	1.94 (49.3)	0.97 (24.6)	0.44 (11.2)	5/32 (4.1)	1.69 (42.9)	1.53 (38.9)	29/32 (23.1)
<input type="checkbox"/> 461-FX2-5L										
<input type="checkbox"/> 461-FN2-4	1/8 Female NPT	0.062 (1.6)	0.07	1.55 (39.4)	0.88 (22.4)	0.44 (11.2)	5/32 (4.1)	1.69 (42.9)	1.53 (38.9)	29/32 (23.1)
<input type="checkbox"/> 461-FN2-5L										
<input type="checkbox"/> 4610-FN8-4	1/2 Female NPT	0.406 (10.3)	3.50	3.13 (79.5)	1.56 (39.6)	0.69 (17.5)	3/8 (9.7)	2.43 (61.7)	3.00 (76.0)	1 1/2 (38.1)
<input type="checkbox"/> 4610-FN8-5L										

6- & 7-way Valve

<input type="checkbox"/> 460-FX1-6	1/16" VFK	0.052 (1.3)	0.05	1.94 (49.3)	0.97 (24.6)	0.44 (11.2)	5/32 (4.1)	1.69 (42.9)	1.53 (38.9)	29/32 (23.1)
<input type="checkbox"/> 460-FX1-7										
<input type="checkbox"/> 461-FX2-6	1/8" VFK	0.062 (1.6)	0.07	1.94 (49.3)	0.97 (24.6)	0.44 (11.2)	5/32 (4.1)	1.69 (42.9)	1.53 (38.9)	29/32 (23.1)
<input type="checkbox"/> 461-FX2-7										

Crossover(4-, 6-way) Valves

4-way Valves

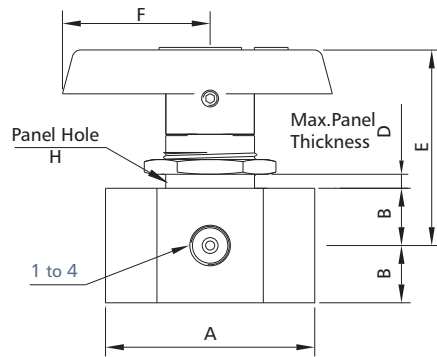

6-way Valves

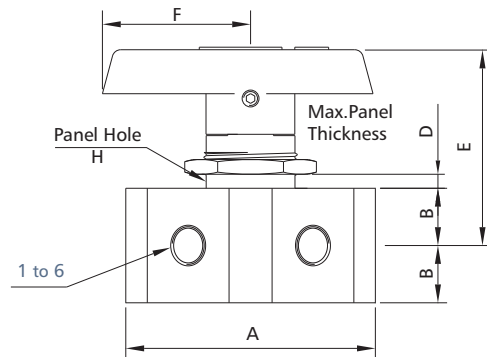

Special Flow Pattern

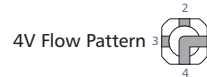
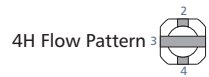

Basic Ordering Number	Connection Type and Size	Orifice in. (mm)	Cv	Dimension, in.(mm)						
				A	B	D	E	F	H	
4-way Valve										
□□460-FX1-4C	1/16" VFK	0.052 (1.3)	0.06	1.55 (39.4)						
□□461-FX2-4C	1/8" VFK	0.062 (1.6)	0.08	1.95 (49.5)	0.44 (11.2)	3/16 (4.8)	1.68 (42.7)	1.53 (38.9)	29/32 (23.1)	
□□461-FN2-4C	1/8 Female NPT			1.55 (39.4)						
□□467-FN8-4C	1/2 Female NPT	0.281 (7.1)	1.60	3.13 (79.5)	0.69 (17.5)	3/8 (9.7)	2.43 (61.7)	3.00 (76.2)	1 1/2 (38.1)	
6-way Valve										
□□460-FX1-6C	1/16" VFK	0.052 (1.3)	0.06	1.95 (49.5)	0.44 (11.2)	3/16 (4.8)	1.68 (42.7)	1.53 (38.9)	29/32 (23.1)	
□□461-FX-6C	1/8" VFK	0.062 (1.6)	0.08							

Bottom Screw Panel Mounting Options

Remark

The bottom screw panel mounting options are not available on angle-pattern valves, 3-way valves, 6-way valves, 7-way valves.

Mounting Dimension

2-way

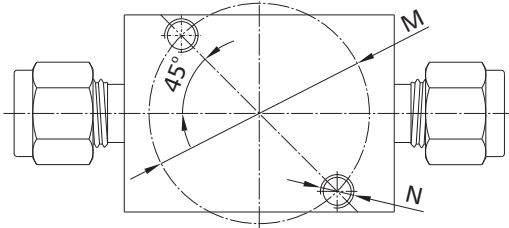

4-way

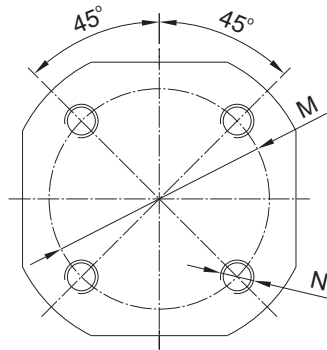

5-way

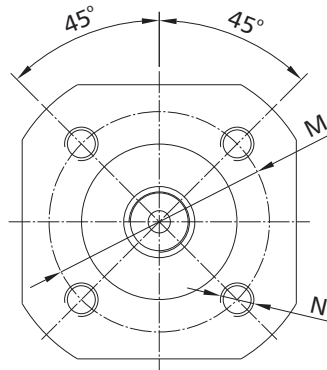

	Orifice in. (mm)	Dimensions, in. (mm)	
		M	N
2-way	0.052~0.125 (1.3~3.2)	0.625 (15.88)	M2.5 x 0.45 deep 6 mm (0.24")
	0.187 (4.8)	0.875 (22.23)	M3 x 0.5 deep 6 mm (0.24")
	0.281 (7.1)	1.25 (31.75)	M5 x 0.8 deep 6 mm (0.24")
	0.406 (10.3)	1.625 (41.28)	M5 x 0.8 deep 6 mm (0.24")
4-way	0.052~0.062 (1.3~1.6)	1.25 (31.75)	M5 x 0.8 deep 6 mm (0.24")
	0.281 (7.1)	2 (50.8)	M5 x 0.8 deep 6 mm (0.24")
5-way	0.052~0.062 (1.3~1.6)	1.25 (31.75)	M5 x 0.8 deep 6 mm (0.24")
	0.406 (10.3)	2 (50.8)	M5 x 0.8 deep 6 mm (0.24")

46 Series How to Order

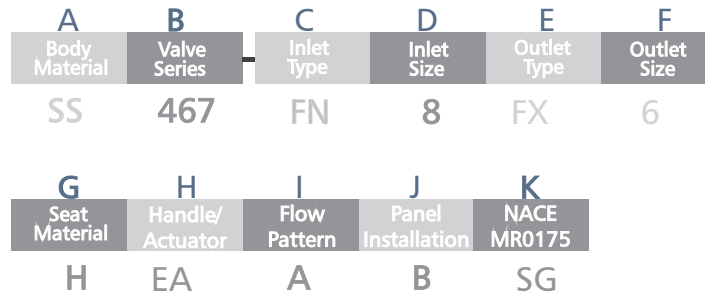

A	Body Material
SS:	316 SS
6L:	316L SS
S4:	304 SS
4L:	304L SS
D5:	Duplex 2205
D7:	Duplex 2507
TI:	Titanium
A20:	Alloy 20
M:	Alloy 400
INC:	Alloy 600
HC:	Alloy C-276

B	Valve Series
460:	46 Series with 0.052" (1.3 mm) Orifice Ball Valves
461:	46 Series with 0.062" (1.6 mm) Orifice Ball Valves
462:	46 Series with 0.093" (2.4 mm) Orifice Ball Valves
463:	46 Series with 0.125" (3.2 mm) Orifice Ball Valves
464:	46 Series with 0.165" (4.2 mm) Orifice Ball Valves
465:	46 Series with 0.187" (4.7 mm) Orifice Ball Valves
466:	46 Series with 0.25" (6.4 mm) Orifice Ball Valves
467:	46 Series with 0.281" (7.1 mm) Orifice Ball Valves
4610:	46 Series with 0.406" (10.3 mm) Orifice Ball Valves

CE	Inlet/Outlet Type
FN	Female NPT
N	Male NPT
FR	Female BSPT
RT	Male BSPT
FM	Female ISO (for MRP)
MS	Male ISO (for MRG)
FP	Female BSPP (for RP)
BP	Male BSPP (for RG)
FX	Fractional Tube Fitting
MX	Metric Tube Fitting

DF	Inlet/Outlet Size
2	1/8"
4	1/4"
6	3/8" or 6 mm
8	1/2" or 8 mm
10	10 mm
12	3/4" or 12 mm
14	14 mm or M14 x 1.5
16	1" or 16 mm
18	18 mm

G	Seat Material
Standard with Virgin PTFE	
H	UHMWPE

H	Handle/Actuator
Standard with Balck Nylon Handle	
EA	90°Electric Actuator
EX	180°Electric Actuator
CS	90°Normally Closed Spring Return Pneumatic Actuator
OS	90°Normally Open Spring Return Pneumatic Actuator
DA	90°Double Acting Pneumatic Actuator

I	Flow Pattern
Standard is Straight Flow	
A	Angle
3L	3-way L Type
3HL	3-way HL Type
4L	4-way L Type
4C	4-way C Type
4H	4-way H Type
4HL	4-way HL Type
4V	4-way V Type
5L	5-way L Type
5H	5-way H Type
5HL	5-way HL Type
5LV	5-way LV Type
6L	6-way L Type
6C	6-way C Type
7L	7-way L Type

J	Panel Installation
Standard with Panel Nut	
B	Valve Body Bottem Screw

K	NACE MR0175
Standard with no NACE applicable	
SG	With NACE MR0175

Remark:

- Standard thread pitch for metric threads are as follows:
M10 and below: 1 mm
M12 to M24: 1.5 mm
Standard thread pitch should be ignored in the ordering
NFmber, others should be specified.



VFK

VFK FLUID CONTROL CO.,LTD

Add:No.18 Danyan Road,Fenghuang Industrial Park,Danyang,Jiangsu,P.R.China

Tel: 0086-511-86197685

Fax: 0086-511-86535052

Http://www.vfkgroup.com